



LEGISLATIVE ASSEMBLY

STANDING COMMITTEE ON PUBLIC WORKS

REPORT

NSW
SCHOOL FACILITIES

Report No.6

November 1997

ISBN: 0731097408

**LEGISLATIVE ASSEMBLY
STANDING COMMITTEE ON PUBLIC WORKS**

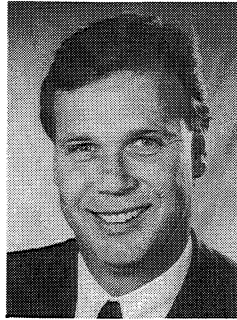

**Mr Paul Crittenden MP
CHAIRMAN**



Mrs Diane Beamer MP



Mr Andrew Humpherson MP



Mr Jeff Hunter MP

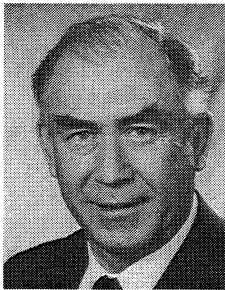

Mr John Price MP

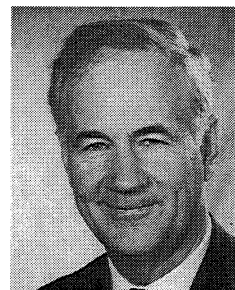

Mr Bill Rixon MP



The Hon George Souris MP



**Mr Tony Stewart MP
VICE-CHAIRMAN**

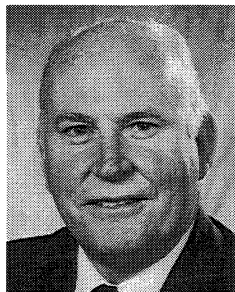

Mr Gerry Sullivan MP

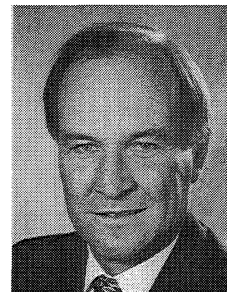

Mr Tony Windsor MP

SECRETARIAT

Bill Dunbar, *Director*
Chris Denney, *Research Officer*

Ian Thackeray, *Senior Project Officer*
Natasha O'Connor, *Committee Officer*

Room 813 Parliament House Macquarie Street Sydney 2000
Telephone: 02 9230 3308 **Facsimile:** 02 9230 3309

TERMS OF REFERENCE

That the Standing Committee on Public Works inquire into and report on least cost construction strategies for school facilities in NSW, in particular the relative costs and benefits to the community of demountable school buildings as opposed to lightweight school buildings.

This inquiry should consider:

- Construction and life cycle costs;
- The current circumstances in which demountable accommodation is being used;
- Whether facilities are of an appropriate standard to facilitate high technology learning;
- The compatibility of lightweight buildings with older school facilities when used as additions;
- Environmental sustainability especially energy management; and
- Future strategies for the provision of appropriate school accommodation especially to high-growth areas of NSW.

TABLE OF CONTENTS

Chairman's Foreword	1
History and Functions of the Committee	3
The Current Inquiry	5
Executive Summary	7
Recommendations	9

CHAPTER 1 **The Planning and Construction of NSW Schools**

1.1	Introduction	11
1.2	The History of School Facilities in NSW	13
1.3	Current Department of School Education (DSE) Education Strategies	16
1.3.1	Statistical Overview of NSW Schools	17
1.4	Planning School Facilities in NSW	19
1.5	The Roles of the DSE and the DPWS in the Planning Process	22
1.6	Long Range Planning Issues	25
1.6.1	The Urban Development Program (UDP)	31
1.6.2	Urban Regeneration	34
1.6.3	The Urban Management Committee of Cabinet	37
1.7	Current and Projected NSW Demographic Patterns	40
1.7.1	Population Size, Distribution and Age	43
1.7.2	School Enrolments	44
1.7.3	Fertility Rates	45
1.7.4	Intrastate Migration	45
1.8	School Asset Management in NSW	47
1.8.1	The Concepts of Macro and Micro Planning	47
1.8.2	The Features of a Comprehensive Asset Management System	48
1.8.3	The Recent Implementation of a Comprehensive Asset Management System in NSW	50
1.9	The Facilities Maintenance Contract System	54
1.10	Relations Between State Government Agencies and Local Government	61
1.11	Comments	64

CHAPTER 2 Lightweight Accommodation in NSW Schools

2.1	The Core Plus System	66
2.2	Types of Permanent Lightweight Buildings	67
2.2.1	The Component Design Range (CDR)	67
2.2.1.1	CDR: Post-Occupancy Evaluations	69
2.2.2	Kit Buildings	72
2.2.2.1	North Coast Kit (NCK) Buildings	74
2.2.3	Design Innovations in ACT Schools	78
2.3	Demountable Buildings	80
2.3.1	Types, Numbers and Value of Demountables	81
2.3.2	Demountable Uses	84
2.3.3	Allocation of Demountables	85
2.3.4	Demountable Movements	86
2.3.5	Refurbishment Costs	89
2.4	Evidence to the Committee on Demountable Accommodation	92
2.5	Comparison of Lightweight and Demountable Buildings	101
2.6	Life Cycle Costings	106
2.7	Compatibility with Existing School Facilities	109
2.8	Relocatable Accommodation	111
2.9	Shared Facilities	117

CHAPTER 3 High Technology Learning in NSW School Facilities

3.1	High Technology Learning	124
3.2	High Technology Learning and NSW School Facilities	127
3.2.1	Upgrading Existing Facilities	129
3.2.2	CDR and Kit Facilities Design	130
3.2.3	Demountables	132

CHAPTER 4 The Environmental Sustainability of NSW School Facilities

4.1	The Concept of Ecologically Sustainable Development (ESD)	135
4.2	The ESD Policy of the DPWS	136
4.2.1	DPWS Environment Policy	137
4.2.2	Environmentally Friendly Materials and Products Policy	137
4.2.3	Conservation of Biological Diversity	138
4.2.4	Waste Management	139

4.3	The Environmental Impact of School Facilities	140
4.3.1	CDR and Kit Facilities	141
4.3.2	Demountables	144

APPENDICES

<i>Appendix 1</i>	DSE and DPWS - Respective Accountabilities for School Facilities
<i>Appendix 2</i>	School Populations - Far North Coast 1977 - 1996
<i>Appendix 3</i>	Core Plus System - A Guide
<i>Appendix 4</i>	Project Timeline - Barnsley Public School
<i>Appendix 5</i>	Component Design Range - A Guide

- Proceedings of the Committee
- List of Submissions
- List of Witnesses
- List of Sources
- List of Tables
- List of Acronyms and Abbreviations
- Glossary
- List of Maps
- Maps

CHAIRMAN'S FOREWORD

The Report on NSW School Facilities represents the first time that the array of publications produced by the NSW Department of School Education (DSE) about the planning and construction of schools has been consolidated into a single document and made available to the public.

It is a truism that education is the future of this nation.

All Members of Parliament are deeply concerned about ensuring equitable educational opportunities. They witness firsthand the problems of local schools in coping with enrolment surges. They see and hear about educational difficulties with demountable buildings. Their own children use such facilities.

The Committee therefore approached this inquiry with a critical eye.

The Terms of Reference were confined to the cost and benefits to the community of lightweight school accommodation. This means that the focus was the primary school system.

The Committee reviewed the Component Design Range (CDR) of permanent lightweight accommodation being designed and built by the DSE in collaboration with the Department of Public Works and Services (DPWS).

It supports the CDR program as a cost effective solution to the provision of safe, secure and flexible learning spaces for children in NSW primary schools.

The Committee also examined innovative Kit buildings which have been successful in augmenting existing facilities, especially in growth areas and smaller regional schools. There is a very high satisfaction rating from users of these permanent facilities.

In many respects, this inquiry was an eye-opener for the Committee.

Submissions from key stakeholders acknowledged significant improvements in the performance of the DSE in recent years.

The current administration of the DSE is to be congratulated for its recent innovations in cost effective school facilities design, asset management and maintenance provision. Mr David Rowland, Director of Properties, has been prominent in this process. The constructive role of the DPWS should also be noted.

The ability of the DSE and the DPWS to find innovative ways of meeting community expectations regarding the quality of schools is a model for all government agencies.

In closing, I would like to thank officers of the DSE who assisted the Committee during its site inspection of the NSW North Coast.

I would also like to thank Mr Tony O'Donnell of the Catholic Education Office for the Archdiocese of Canberra and Goulburn for offering his time and expertise to the Committee during its inspection of ACT schools.

The Committee believes that this independent examination of the DSE has enhanced the process of innovation and equity in NSW schools. It has also provided a public forum to air stakeholder concerns and seek solutions to some longstanding problems.

This Report is a timely review of recent DSE strategies which points the way forward to further refinements in the planning and construction of school facilities in NSW.



Paul Crittenden MP
Chairman

THE HISTORY AND FUNCTIONS OF THE COMMITTEE

The Standing Committee on Public Works was originally established in New South Wales in 1887. Its operations were suspended in 1930.

It was re-activated by Motion of the Legislative Assembly on 25 May 1995 with the following principle Term of Reference:

That a Standing Committee on Public Works be appointed to inquire into and report from time to time, with the following terms of reference:

As an ongoing task the Committee is to examine and report on such existing and proposed capital works projects or matters relating to capital works projects in the public sector, including the environmental impact of such works, and whether alternative management practices offer lower incremental costs, as are referred to it by:

- the Minister for Public Works and Services, or
- any Minister or by resolution of the Legislative Assembly, or
- by motion of the Committee.

The Committee comprises 10 members of the Legislative Assembly, six members representing the Government, three members representing the Opposition, and one Independent member to be nominated in writing to the Clerk of the Legislative Assembly.

The current Members of the Committee are:

- Mr Paul Crittenden MP, Chairman.
- Mr Tony Stewart MP, Vice Chairman.
- Mrs Diane Beamer MP.
- Mr Andrew Humpherson MP.
- Mr Jeff Hunter MP.
- Mr John Price MP.
- Mr Bill Rixon MP.
- The Hon George Souris MP.
- Mr Gerry Sullivan MP.
- Mr Tony Windsor MP.

The Committee has the power to make visits of inspection within New South Wales and other states and territories of Australia.

The Committee's intended role was clarified in a speech given to the Parliament by the Hon Paul Whelan, Minister for Police and Leader of the Government in the House, on 25 May 1995:

The Committee may inquire into the capital works plans of State-owned corporations and joint ventures with the private sector. The Committee will seek to find savings in capital works programs whilst achieving a net reduction in environmental impacts by public sector developers. The Committee's work is expected to provide incentives to the public sector to produce more robust cost-benefit analyses within the government budgetary process and to give more emphasis to least-cost planning approaches. The Committee will be sufficiently resourced to enable it to conduct parallel inquiries into specific projects and capital works programs generally.... it will have sufficient resources to inquire into the capital works program of all government agencies whose capital works programs affect the coastal, environmental and transport sectors.

The Standing Committee on Public Works absorbed the functions of the Standing Committee on the Environmental Impact of Capital Works.

The Committee has tabled the following Reports:

- State Infrastructure Requirements for Sydney West Airport (Report No.1, December 1995).
- First Report on Development and Approval Processes for NSW Capital Works (Report No.2, October 1996).
- Report on the Lake Illawarra Authority (Report No.3, November 1996).
- Report on Wyong Station Interchange (Report No.4, April 1997).
- Report on the National Conference of Australian Parliamentary Public Works and Environment Committees, Brisbane 1997 (Report No.5, October 1997).

The next stage of the ongoing Inquiry into Development and Approval Processes for NSW Capital Works began in June 1997 with a public hearing and site inspection of Olympics facilities.

THE CURRENT INQUIRY

The Inquiry into NSW School Facilities arose out of the findings of the Committee's ongoing Inquiry into Development and Approval Processes for NSW Capital Works.

At a public hearing on 13 May 1996, Ms Jan McLelland, Deputy Director-General (Resources), and Mr David Rowland, Director of Properties, gave evidence about the strategic planning processes used by the Department of School Education to develop, prioritise and construct school facilities.

The evidence of Ms McLelland and Mr Rowland - along with a departmental submission tabled at the hearing of 13 May 1996 - is contained in the *First Report on Development and Approval Processes for NSW Capital Works* (Report No.2 of the Committee, October 1996).

The information gained at this briefing series resulted in the Committee taking the decision to look in more detail at this issue, paying particular attention to the relative merits of lightweight and relocatable school facilities in NSW primary schools.

The Inquiry into NSW School Facilities was initiated with the following Terms of Reference:

That the Standing Committee on Public Works inquire into and report on least cost construction strategies for school facilities in NSW, in particular the relative costs and benefits to the community of demountable school buildings as opposed to lightweight school buildings.

This inquiry should consider:

- construction and life cycle costs;
- the current circumstances in which demountable accommodation is being used;
- whether facilities are of an appropriate standard to facilitate high technology learning;
- the compatibility of lightweight buildings with older school facilities when used as additions;
- environmental sustainability especially energy management; and
- future strategies for the provision of appropriate school accommodation especially to high-growth areas of NSW.

The Committee adopted the following procedures to ensure that its inquiry was widely-publicised and that all institutions, groups and individuals with an interest in provision of high quality and cost effective school facilities were given the opportunity to contribute their suggestions:

- Publicly calling for submissions in major newspapers.
- Conducting site inspections. The Committee inspected relocatable buildings in the Australian Capital Territory and Queanbeyan and school accommodation in the Tweed

- Valley / Ballina district with officers of the Department of School Education.
- Holding public hearings. The Committee received evidence from four organisations at public hearings held at Parliament House in Sydney. A complete list of witnesses is contained in the appendices at the end of this report.

The structure of the report is dictated by the Terms of Reference, which require the Committee to concentrate on the relative merits of demountable and lightweight accommodation as school facilities in NSW primary schools.

As a result, the Committee has not focused on NSW secondary schools - where so-called lightweight facilities are not used - although related matters which have emerged during the course of this inquiry are considered.

Chapter 1 provides a historical background to the provision of educational facilities in NSW, details the objectives of the Department of School Education and looks at the capital planning process including demographic forecasting. It examines recent innovations by the DSE and the DPWS to improve school facilities such as the new Asset Management System, Schools Facilities Standards and Facilities Maintenance Contract system. It also looks at problems with local government over DA approval.

Chapter 2 examines the current uses of lightweight and demountable buildings in NSW schools and their comparative construction and life-cycle costs. Innovative design features in North Coast Kit buildings and ACT Catholic schools are considered.

Chapter 3 deals with the capacity of demountable and lightweight buildings to provide environments which meet the requirements of contemporary technology.

Chapter 4 assesses environmental sustainability.

The result is a comprehensive report that consolidates a huge amount of documentary material and data on the NSW education system into a single document for the first time.

This report is a valuable resource to everyone with an interest in the NSW education system.

It also acts as a timely review of the strategies being pursued by the DSE to deliver on its commitment to provide cost effective, high quality school accommodation in NSW in the twenty-first century.

EXECUTIVE SUMMARY

The capital works planning process of the Department of School Education represents an efficient and accountable system for the equitable delivery of school facilities throughout NSW.

It is based on a working agreement between the Department of School Education and the Department of Public Works and Services which offers an excellent example to other government agencies of a constructive working document which clearly delineates the responsibilities of each party in the delivery of schools infrastructure.

There is ample evidence that the Department of School Education - in collaboration with the Department of Public Works and Services - is finding innovative ways of providing optimal and cost effective learning environments.

Recent measures include the development of new Schools Facilities Standards and a comprehensive Asset Management System.

These management tools, in turn, have enabled the Department of School Education and the Department of Public Works and Services to completely restructure the maintenance system for NSW schools by the introduction of Facilities Maintenance Contracts.

These initiatives will enable the Department of School Education to identify and correct infrastructure shortfalls, thereby promoting educational equity across NSW.

The Component Design Range has been developed by the Department of School Education and the Department of Public Works and Services as an economical way of delivering good quality primary school facilities for the Core Plus system.

Some refinements to the flexibility and range of the Component Design Range of school facilities would improve its performance, particularly in adverse climatic conditions.

The Department of School Education is actively engaged in identifying ongoing refinements to the Component Design Range through its Post-Occupancy Evaluation surveys.

The Post-Occupancy Evaluation of new school facilities is working well but its effectiveness would be further enhanced if all teachers were actively encouraged to complete the surveys.

Participation rates of less than 50% at some schools are not satisfactory. In addition, the Post-Occupancy Evaluation process could encourage more student, parent and community input.

The Department of School Education has also developed an innovative range of Kit lightweight buildings which provide high quality, cost effective additions to schools with sustained enrolment increases.

Kit buildings have been particularly successful in growth areas like the Central Coast. A high level of teacher, pupil and parent satisfaction has been recorded with them. They provide the Department of School Education with a viable alternative to demountables.

The new Asset Management System and improved demographic projections will enable the Department of School Education to identify schools where Kit buildings will be required and construct these facilities to meet increased student numbers. This will further reduce the use of demountables as de facto permanent facilities.

While there is considerable user dissatisfaction with demountable buildings, there is acknowledgement that they are an essential part of a flexible school facilities system.

The decision to review the design of demountables in accordance with Passive Solar & Ecologically Sustainable Development Design Principles indicates that the Department of School Education and the Department of Public Works and Services have recognised deficiencies in the thermal comfort of demountable accommodation.

This decision also indicates that the Department of School Education and the Department of Public Works and Services are keen to rectify the ‘environmentally unfriendly’ tag attached to demountables.

However, any program to upgrade demountables must be measured against funding allocations across the Department of School Education capital works budget.

In addition, relocatable lightweight buildings being developed by the private sector to meet School Facilities Standards may offer a feasible alternative to demountables. The Department of School Education should trial this concept on an appropriate scale.

RECOMMENDATIONS

CHAPTER 1

1. The Department of School Education and the Department of Public Works and Services develop formal strategies to enhance opportunities for companies in regional NSW to tender for public works on a level-playing field. (p.61)
2. The Department of School Education and the Department of Public Works and Services review preferred tendering criteria for the Facilities Maintenance Contracts system to ensure that regional companies are not disadvantaged by the tendering process. (p.61)

CHAPTER 2

3. The Department of School Education implement strategies to encourage the completion of Post-Occupancy Evaluation surveys by all staff. (p.72)
4. The Department of School Education promote a more broadly-based survey pool for Post-Occupancy Evaluation surveys including input from students, parents and the community. (p.72)
5. The Department of School Education continue to refine school facilities to enhance their flexibility to meet the specific climatic and site requirements of different regions of NSW.

It is important that the Department of School Education should continue its approach of liaison with relevant officers and professional people from within the region affected. (p.78)

6. The Department of School Education commission the School Building Design and Research Group (SBDRG) to study lightweight facilities constructed by the Catholic Education Office (Archdiocese of Canberra and Goulburn) at St Clare of Assisi Primary School, Conder, ACT with a view to incorporating innovations in the hall and administration block designs into the Component Design Range. (p.80)
7. The Committee endorses the current Department of School Education policy of not purchasing further demountables of the kind currently used in the NSW education system. This policy should continue. (p.101)
8. The Demountable Refurbishment Program be upgraded to address problems with leakage and walkway safety.

In particular, the use of a portable roof canopy over demountable buildings on the

NSW North Coast to stop leakage should be considered for areas of high rainfall, especially where they are being used as libraries or computer rooms. (p.101)

9. **The Department of School Education undertake further analysis of relocatable lightweight school facilities being developed by the private sector with the goal of conducting a trial of these facilities if it is deemed appropriate.**

Relocatable lightweight school buildings which have been specifically designed to meet Schools Facilities Standards may prove invaluable as a replacement for the existing stock of demountable buildings as they reach the end of their life-cycle. (p.116)

10. **The Department of School Education consider the development of shared facilities in NSW schools, especially in Urban Development Plan growth areas where there is a longer planning lead time and access to suitable sites. (p.123)**

CHAPTER 3

11. **The Department of School Education review policies relating to high technology learning to ensure that urban growth areas and regional communities are targeted as priority groups for the provision of information technology infrastructure. (p.127)**

12. **The Department of School Education undertake a review of the technological capacity of existing facilities in the NSW education system.**

This review should focus on the ability of existing facilities to meet current and future technology requirements, and the cost of updating these facilities to the appropriate level to enable access to information technology. (p.130)

13. **The Department of School Education equip all new NSW classrooms with cable trays to enable cost effective access to high technology equipment. The installation of cable trays should also be part of the refurbishment of existing facilities. (p.132)**

14. **The Department of School Education and the Department of Public Works and Services review the Component Design Range to ensure that TV/computer points are not located directly under chalkboards in classroom modules. (p.132)**

THE PLANNING AND CONSTRUCTION OF NSW SCHOOLS

1.1 Introduction

School education constitutes a critical investment in Australia's future. This fact has become abundantly clear throughout the world in recent years as issues of national economic competitiveness have driven improvements towards the delivery of quality education. It is an especially important issue in developed societies with an aging population. The smaller proportional workforce of the future must be able to generate sufficient wealth to maintain the social systems expected by our culture. This means that the population must be skilled in the technologies which will provide well-paid employment in the global economy of the twenty-first century.

Many educationalists have debated the term "quality" education and attempted to define its components. Regardless of the changes which may occur in teaching and learning processes and curricula, school planners in the United States of America have concluded that the standard of school accommodation has a decisive capacity to either enhance or detract from the learning process. These studies reveal a correlation between learning and the environment in which learning takes place. The delivery of "quality" educational services, therefore, is now commonly equated with certain types and standards of school infrastructure.

Analysis in the United States of America has been focussed on determining the relevant inputs for high performance amongst school students of all ages. The Carnegie Foundation for the Advancement of Teaching (1988) found that student's attitudes about education are a direct reflection of their learning environment.¹ An independent survey of schools in Washington DC by the American Association of School Administrators (AASA) in 1991 concluded that students had the capacity to improve by 5-11% on standardised tests if the physical conditions of their schools improved (Ortiz - 4). McGuffey (1982) and Plumley (1978) also found that obsolete and inadequate school facilities significantly detracted from the learning process (Ortiz - 31).

Given such evidence, decision makers in NSW face the difficult challenge of planning and constructing a congenial school environment within a framework of limited funding resources. They need to focus on present contingencies while at the same time planning the delivery of an education system which will meet the demands of changing curricula, rapid advances in technology, environmental sustainability and altered learning/teaching methodologies.

All these issues impact on the way that school planners accommodate students. Issues of safety,

¹ Ortiz, Flora Ida, *School Housing: Planning & Designing Educational Facilities*, State University of New York Press (New York: 1994), p.4.

comfort, aesthetics, flexibility and environmental responsibility must be incorporated into plans and designs, particularly as the traditional forms of building stock continue to age. The accurate and effective plotting of peaks and troughs in enrolments adds a further dimension to this complex challenge.

The goal must be to ensure that each child in NSW receives equal access to the best prevailing school facilities and that there is equality of outcomes from the education system.

NSW schools now have a construction base that spans one hundred years. Some of these buildings can no longer provide the comfort, style and technological capacity that permit optimal educational performance, let alone contribute in a decisive way to the preservation of the environment.

The community has become increasingly aware of the inadequacy of these forms of accommodation. There is an expectation that school facilities will meet certain standards. In its submission to the Committee (s.6), the NSW Primary Principals' Association stated that:

... all children are entitled to be accommodated on permanent buildings that are safe, comfortable, aesthetically pleasant, adaptable to modern teaching methods, and that minimise the effects of climatic conditions on learning.

School housing differs from other types of capital works in that there exists an inherent assumption that schools symbolise a community's most deeply held beliefs. Beyond consensus that children need to be housed in order to be educated, the school facility must be a place that reflects the value placed by society on children and learning. Issues of safety, wellbeing and aesthetics are related to this cultural ethos.

Decisions to build certain types of school facilities have had enduring consequences for students and the community. They will continue to have the same repercussions in the future.

Building types need to be designed with foresight to allow for future changes to the education system. These changes may be radical and impose tight deadlines.

In education, such changes may result from:

- Changes in the age at which pupils start or leave school.
- Increased participation rates.
- Demographic shifts.
- Rationalisation or reorganisation of school provision.
- The creation of new fields of study or changed balance between existing disciplines.
- Changes in teaching and learning methods, particularly in relation to new technology.
- Changes in the size of teaching groups.

The introduction of the Wyndham Scheme in NSW in 1962 is an example of the type of

fundamental systemic change which can completely alter the structure and objectives of the education system. Other changes are more temporary in nature.

Appropriate, flexible design should allow the users of a school facility to meet changing needs without expensive alterations.

In the next section, the Committee outlines the history of school facilities in NSW as a means of demonstrating how the existing school system and individual school facilities came into existence.

1.2 The History of School Facilities in NSW

The history of the provision of school accommodation in NSW has been characterised by consistent attempts to upgrade existing facilities in line with the evolving needs of the education system.

The asset base of the NSW school education system includes buildings that are now over one hundred years old. The simple and austere layout of these older facilities reflects the limited requirements of this era, which focussed on delivering basic education to the school aged population. School buildings reflected this traditional approach to learning with schools designed to meet the basic needs of the users. There was scant regard for user comfort. Students tended to remain in one classroom for the full school year. This reduced the need for classrooms. The occasional visit to a science laboratory or a craft room for practical work meant that building designs were fairly standardised and required limited flexibility. Few of the modern day demands were placed upon school planners to provide facilities which incorporate design flexibility and high environmental standards.

Standard school building designs continued to be used in the construction boom that followed World War II. New forms of frame construction incorporating prefabricated or precast materials were merely incorporated into existing design layouts to meet demands for additional space that arose with the increase in school enrolments.

The introduction of the Wyndham Scheme in 1962 revolutionised education in NSW.

More complex and expensive school structures were suddenly required to meet the demands of an extra school year, increases in the level and length of student enrolments and increased diversity in the school curriculum. There was a need for:

- More classrooms.
- Larger classrooms.
- Specialist teaching rooms.
- Enhanced teacher accommodation.
- Laboratories.
- Expanded libraries.

While new schools could be planned and constructed to cater for the expanded education system, existing schools needed to be expanded and upgraded on existing sites. Often, these sites were small and unsuitable for expansion.

The Department of Education embarked on a major planning program to devise strategies which would minimise costs while maximising the utility, comfort and appeal of school facilities to provide a high standard of education to all students in NSW.

The view emerged at this time that school sites needed to be more compact so that they could be practically managed.

In 1965, the “dough-nut” school was introduced. Its linear design included a single open balcony wrapped around a courtyard. It was designed to allow staged development.

A fifteen percent increase in school enrolments was countered in 1967 by the introduction of the “consortium” school design. This design incorporated larger courtyard blocks and allowed blocks to be joined diagonally tip-to-tip. Unfortunately, this design was inadequate to cope with high noise levels, particularly when large groups gathered. This created significant disturbances to student concentration.

The Study 1, 2 and 3 schools were subsequently introduced as variations on the standard courtyard design. The Study 1 model experimented with a steel framed prefabricated panel system. The Study 2 school became the standard design in 1969. It was based on two level brick construction, which was cheaper than precast or steel frame construction, and provided approximately the same area as the consortium school at 15 percent less cost. Study 2 school design buildings were low maintenance but had a heavy rather than graceful architectural appearance. In response, the more expansive Study 3 variation was introduced in 1973.

Matters of economy encouraged school planners to incorporate a staged development approach to school facilities design. This responded to the incremental growth in new schools from an initial minimum intake of 400 pupils to maximum levels of 1,400 pupils. Staged development remains an essential feature of the NSW education system as it operates today.

The implementation of the Wyndham Scheme led to the development of transportable accommodation to complement a core of permanent school buildings.

Transportable school accommodation was developed as a cost effective option to respond to the speed at which school needs now changed and to curtail the cost of providing permanent accommodation.

Readily transportable and relocatable classrooms, originally known as “Divisible Mobile Classrooms”, designed by the Department of Public Works, were added to the NSW education system in 1965.

These so-called “demountable” classrooms were factory-made and finished at an average cost of \$14 000 per unit (1965 dollars). They replaced traditional portable timber buildings which had been comparatively more expensive to build and difficult to transport. This provided the NSW education system with an “instant” solution to providing temporary facilities for growing schools in NSW. The first demountable classroom was erected at Kingsgrove North High School in 1966.

Funding limitations, burgeoning enrolments and short term approaches to school infrastructure planning have resulted in the permanent use of demountable buildings in the NSW education system.

In its submission to the Committee (s.5), the NSW Teachers Federation outlined the history of this practice:

Common practice ... in the public school system has seen demountable buildings become de facto permanent accommodation. The problem of demountable buildings being used for permanent student accommodation is one that can be traced back to the explosion of births after World War II when the wooden portables were evident. The Federation holds files that trace demountable buildings being used as ‘permanent’ accommodation at least as far back as the mid 70s.

Demountable buildings remain an integral part of education policy in New South Wales.

In 1981, the Department of Education introduced the Core Plus principle for primary schools to respond to demographic trends such as a reduction in the number of children per household.

Under Core Plus, schools are constructed using a number of permanent classrooms which form a ‘core’ school facility. To this core facility, temporary demountable accommodation is added and withdrawn as dictated by cyclical variations in the school population.

For example, a Core 21 school has administration, library, communal and toilet facilities for a projected peak enrolment of 630 pupils in twenty-one Home Bases. Only fourteen of these facilities are permanent Home Bases. The peak enrolment for the school will be carried by seven Demountable Home Bases, which are incorporated into the total school plan.

Generally the Core Plus principle is adopted according to Table 1 below.

TABLE 1: Core Plus Planning Principles

	Core 7	Core 14	Core 21
Range of Home Base Nos	5-10	11-17	18-21
Permanent Home Bases	5	10	14
Demountable Home Bases	2	4	7

The number of permanent classrooms constructed as part of the Core Plus principle is dependant upon student enrolment projections, which are calculated 3-5 years in advance by departmental demographers.

As enrolments grow to a peak, additional classrooms are provided in the form of demountable buildings. These demountable buildings are then removed from the school site when enrolments fall. This means that permanent facilities continue to operate at close to full capacity while the demountable stock can be reallocated to schools experiencing peaks in enrolment.

The deployment of demountable buildings to provide temporary accommodation is integral to the Core Plus concept. It offers a low cost strategy that allows a high level of flexibility.

The Core Plus system will be considered in detail in the next chapter as part of an examination of alternate planning and building design options. This examination will focus on the Component Design Range (CDR) of lightweight buildings, which has been developed as a system of cost effective, high quality primary school facilities.

In the next section, the Committee considers the current education strategies in place in NSW as a preliminary step to determining their impact on school facilities.

1.3 Current Department of School Education (DSE) Strategies

The Department of School Education (DSE) has attempted to develop strategies which support rapidly changing technology and curriculum demands and address shortfalls in school facilities provision while remaining within the parameters of existing funding levels.

The Minister for Education and Training announced a substantial restructuring of the DSE in August 1995. It was completed in December 1996.

The restructuring of the DSE is designed to utilise all available resources and shape them into a new form of administration driven essentially by educational imperatives. Restructuring aims to eliminate administrative duplication and waste, thereby providing a leaner bureaucracy focussed on improving the quality and range of services available locally to schools and teachers. It will also contribute to the Government's deficit reduction strategy.

The restructured DSE contains the following features:

- Reduction of the existing three-tier arrangement of clusters, regions and state office into a simplified two-tier structure - districts and head office.
- Replacement of ten existing regions with forty districts to provide enhanced support for teacher and schools. The district office would not be a separate layer of administration.
- Grouping of 2 226 existing schools into forty school districts, each with a district office of twenty staff, a district superintendent and district office support staff.

The current objectives for the NSW education system were documented in Agenda 96. They are summarised by the slogan: "Teaching traditional values in safe and happy schools; aiming for excellence in high-tech classrooms; providing a fair go for all."

As part of this policy, the NSW Government has allocated \$177 million to a four-year Computers in Schools program to ensure that students have the tools to meet the challenges of the twenty-first century.

The goal of the Computers in Schools Program is to reduce the computer-to-student ratio to 1:8 by 1998.

Each school in NSW was recently provided with an enhanced computer system, Internet compatible software, modem, and telephone lines for access to the Internet. The cost of this component of the program was \$24 million. In addition, 15 000 teachers are to be trained in the use of technology in the classroom.

The DSE corporate goals have recently been updated in Agenda 97:

- Getting the foundation right.
- Excellence in teaching and learning.
- Partnerships in public education.
- Safe, challenging and creative schools.
- A fair go for all.

In addition to updating the DSE corporate goals in Agenda 97, the NSW Government announced a number of major reforms to the education system in early 1997.

This Report by the Committee reviews the strategies being implemented by the DSE to maintain the relevance of school facilities to a rapidly changing education environment and investigates the current scope of demountable building use in NSW.

The next sub-section provides a statistical overview of NSW school facilities as the basis for this examination.

1.3.1 Statistical Overview of NSW Schools

The Committee initially reviewed the DSE asset base in May 1996 as part of its ongoing Inquiry into Development and Approval Processes for NSW Capital Works. As part of the DSE submission to the Committee for the Inquiry into NSW School Facilities, the DSE provided data on the relative proportion of funding that it receives from consolidated revenue and the size and value of its DSE asset base.

It showed that the DSE received \$3 719 million (or 19%) of consolidated revenue allocated for recurrent services expenditure.

The NSW Budget for 1996/97 allocated \$151 million to the DSE schools capital program, which constituted 48% of total capital budget allocation of \$306 million. Education as a whole received a 4.8% increase in funds in 1996/97.

The NSW Budget for 1997/98 allocated a further \$129.8 million to the schools capital program, of which \$20 million was directed to commence major works and almost \$70 million to works in progress.

The Committee consolidated data to compose a total picture of school assets in NSW in 1996:

Enrolments in Government Schools

• total number of students	756 000
• primary students	446 722
• secondary students	305 396
• special needs students	3 789

Real and Built Assets

• value of sites	\$2.6 billion
• replacement value of buildings	\$10.5 billion
• value of demountables	\$460 million
• floor area of buildings	6.2 million sq.m
• average age of buildings	33.4 years

Numbers of Schools

• infants schools	18
• primary schools	1,633
• central schools	64
• high schools	388
• schools for specific purposes (SSPs)	104
• field study sites	19
• preschools	75
• total schools	2226

School Buildings

• total school buildings	15 800
• total value	\$10.5 billion
• total demountable buildings	5 600
• learning spaces	4 700
• total value	\$460 million.

Average Age of School Facilities

• primary schools	36.2 years
• secondary schools	26.4 years
• central schools	32.6 years
• SSPs	21.1 years

This data provides a macro picture of the school system in NSW.

However, it does not seek to provide the detailed micro level demographic data which determines the distribution of school facilities in NSW.

The DSE has significantly upgraded its asset management system in 1996-97 to improve its knowledge of the condition and distribution of its assets so that better facilities planning can be implemented. The Committee looks at the new asset management system later in this chapter.

In the next section, the Committee outlines the methodology for planning school facilities in NSW.

1.4 Planning School Facilities in NSW

In New South Wales, the DSE works in conjunction with the Department of Public Works and Services (DPWS) to plan and build new school facilities.

The initial planning phase is primarily the responsibility of the DSE and relies heavily on demographic projections. Once it has been established that facilities are needed, the DSE determines an operational time-frame for construction and prioritises the works in the DSE capital works program.

In its submission to the Committee (s.7), the DSE summarised the criteria used to determine whether facilities should be constructed:

- Establishing demographic need.
- Establishing priority.
- Site selection matters.
- Environmental concerns.
- Practical considerations of resource provision including life-cycle costing.
- Consideration of the impact of recent developments in alternative provision.
- Consideration of the impact of recent developments in educational practice.
- Consideration of special factors pertaining to the area and community.

The capital works strategic planning process of the DSE is governed by the following imperatives:

- DSE corporate goals in Agenda '96 and Agenda '97.
- 3-5 year rolling plan.
- demographic trends.
- curriculum needs.
- government priorities.

There are six stages to the capital works planning process:

1. **Nominations.** Calling for nominations for new schools or expanded school facilities.
2. **Evaluation.** Assessment of nominations.
3. **Options.** Consideration of alternatives to construction.
4. **Priorities.** Ordering the capital works program based on issues of equity and funding.
5. **Detailed Planning.** Thorough analysis of prioritised nominations.
6. **Programming.** Ensuring project delivery on time and within budget.

Nominations for new schools or expanded school facilities derive from four sources:

- Systematic department review.
- Priorities determined by the Urban Development Program (UDP).
- School communities.
- Members of Parliament.

The **Evaluation** stage requires:

- Demographic analysis.
- Condition assessment of existing facilities.
- Accommodation audit.
- Comparison of existing facilities with entitlement.
- Consideration of issues such as isolation.

The **Options** stage involves considering alternatives such as:

- Utilising capacity in nearby schools.
- Providing demountable accommodation for peak enrolment.
- Upgrading existing school facilities.
- Building a new school.
- Assessing the nomination as a low priority in comparison with other nominations.

The **Priorities** stage determines which category the nomination will be fitted into in the DSE capital works program.

These stages are:

- Essential new works.
- Staged follow-on works.
- Additional buildings.
- Conversion of existing accommodation to enhanced use.

Issues of health and safety are also a primary consideration in this stage.

The **Detailed Planning** stage represents the point at which the nomination is subjected to exhaustive analysis to justify its necessity and cost.

The following assessments may take place:

- Site analysis.
- Concept options.
- Community consultation.
- Cost control - apply facility standards.
- Value management studies.
- Economic appraisal.
- Life cycle costings.
- Planning audit.
- Buildability audit.
- Applicability of standard designs.
- Timing.
- Method of project delivery.

The final stage, **Programming**, enforces strict requirements for:

- Project delivery on time.
- Project delivery within budget.
- Cash flow management.

In addition to these stages in the capital works planning and construction process, the role of **post-occupancy evaluations** should also be noted as a method of reviewing the effectiveness of existing facilities designs.

A time line for a typical upgrade under the DSE capital works program at Barnsley Public School is contained at Appendix 4.

In the rest of this introductory chapter, the Committee looks in more detail at this process for prioritising and planning school facilities.

The Committee also looks at the design and construction strategies employed by the DSE to provide satisfactory accommodation for students while minimising costs.

In the next sub-section, the Committee examines the close interaction between the DSE and the Department of Public Works and Services (DPWS) in providing the best possible school environment through their capital works program, school facilities standards and asset management system.

1.5 The Roles of the DSE and the DPWS in the Planning Process

The DSE and the DPWS are jointly responsible for the provision of school facilities, with the DPWS assuming more responsibility as the process moves towards construction.

The departments have initiated a program of co-operation to ensure that the community retains a high level of confidence in the way education assets are constructed and managed.

Both departments share roles and responsibilities which focus on:

- Delivering new school places in developing areas throughout the State.
- Upgrading and adding to existing schools.
- Maintaining existing assets.
- Disposing of assets.
- Provision of office accommodation within schools.

A Working Agreement between the DSE and the DPWS was implemented in June 1996 to clearly delineate these roles and responsibilities. It formalises the relationship that has developed between the departments and establishes the strategic focus for the interaction between them until June 1999.

The Working Agreement aims to minimise duplication between the two organisations, clearly identify key accountabilities and focus each organisation on those areas where they have greatest responsibility.

The DSE's major role is to ensure that school facilities assist learning and teaching and effectively utilise school assets and resources on a consistent basis throughout the system.

The role of the DPWS is that of an 'enabler' for these DSE objectives. The DPWS provides advisory services and design, building and maintenance programs on a fee-for-service basis.

In evidence before the Committee, Mr John Zahn, Schools Section Manager of the DPWS, summarised the tenets of the Working Agreement:

We have a working agreement which is basically a strategic partnership with the DSE, properties directorate. This working agreement acknowledges the strengths of both departments and is complementary in trying to reduce overlap between both departments and to increase efficiency in both departments. It is complementary in that DSE has a responsibility to the school community and the community at large for the delivery of education services.

The Department of Public Works and Services has responsibility to the DSE to manage consultants and contractors for the delivery of approved projects and approved programs. The department manages the process for the DSE after it has been through its internal process to Treasury and the

nomination process to come up with approved projects. (47)

The Working Agreement between the DSE and the DPWS results in a 3-5 year Strategic Program being developed to:

- Provide reliable technical advice and innovation.
- Maximise value from the budget provided to the DSE.
- Ensure timeliness of service delivery.
- Incorporate current trends, standards and best practice.
- Meet educational needs and broad range options.

The Strategic Program promotes the equitable statewide provision of school facilities.

The relative accountabilities of the DSE and the DPWS for planning over the different facets of the school asset portfolio is summarised in Table 2.

TABLE 2: DSE/DPWS Strategic Planning and Development

Contribution	Accountability	
	DSE	DPWS
• Identification of opportunity	90	10
• Educational data & analysis on which to base decisions	95	5
• Technical data & analysis on which to base decisions	50	50
• Learning and teaching directions	95	5
• Policies including OH&S	60	40
• Innovation	50	50
• Technical expertise	5	95
• Asset information expertise	60	40
• Strategic environmental advice	30	70
• Probity management	10	90
• Whole of government approach	10	90
• Understanding of the marketplace	10	90

Source: DSE and DPWS Working Agreement 1996, p 13.

A more detailed breakdown of the information in Table 2 is contained at Appendix 1 of this Report.

It should be noted, however, that the DSE retains almost total responsibility for strategic planning and development; in other words, those issues which relate directly to education. The

DPWS is introduced into the process to provide technical and design expertise and to oversight tendering processes and the construction phase.

Regular communication between both departments is maintained by:

- Meetings of the School Building Research and Development Group (a joint department unit with educational, technical and research expertise).
- Regular project planning reviews.
- Regular reviews of educational and technical specifications.
- Program status reviews.
- Regular financial monitoring.

The DPWS assumes a large degree of responsibility for the function and appearance of the school environment. It provides guiding input on:

- The marketplace.
- Whole-of-government concepts.
- Environmental issues.
- Trends in design and construction.
- Technical matters.

The DSE/DPWS partnership recognises the importance of cost effectiveness while providing quality infrastructure conducive to optimal student performance.

Least cost construction strategies for school buildings are facilitated by:

- Ensuring the buildability of school designs.
- Selecting materials using life-cycle cost methodology.
- Adhering to universal school facility standards.
- Incorporation of energy efficient technologies.
- Use of environment-friendly building solutions.

Facility standards for all primary and secondary schools in NSW have been created to respond to the specific educational requirements for individual and group spaces. They are applied as a benchmark to ensure equity of access to high quality educational facilities across NSW.

These standards are continually being developed and updated to incorporate:

- Legislative change which meets the requirements of the Building Code of Australia, POPE, Occupational Health and Safety guidelines, disabled access and heritage orders.
- Design components such as furniture, fittings and materials, safety, security, increased environmental awareness and burgeoning technology.

These standards simplify the brief for each project by imposing highly-defined specifications. This

avoids unnecessary duplication in the development of core facility planning and provides uniform guidance to designers. Extensive trialing ensures that the most cost-effective and environmentally acceptable materials and fittings are specified for use in schools.

The goals outlined in the Working Agreement between the DSE and DPWS have been formalised in the Component Design Range (CDR) of buildings.

The CDR offers a comprehensive and flexible building solution which incorporates active and passive energy management strategies to achieve superior comfort conditions. These energy management strategies aim to reduce energy and heating costs through the incorporation of innovative design features. The Committee will discuss CDR buildings in the context of alternative facilities strategies in Chapter 2.

The Working Agreement between the DSE and the DPWS states that the success of their partnership will be measured by:

- Achieving quality schools with high levels of educational functionality.
- Delivering projects on time and within budget.
- Successfully implementing educational innovations.
- The comparative cost of buildings per square metre.

The effectiveness of the learning environment created in NSW will increasingly depend upon the capacity of the DSE and the DPWS to maximise available resources through innovative design and maintenance programs such as the CDR.

The Committee will focus on the relationship between the DSE and the DPWS in later chapters, which specifically deal with the type of accommodation being designed and constructed for NSW schools by these departments.

However, there are important issues to be considered in the remainder of this chapter including the way in which the planning process affects the delivery of school facilities and the type of accommodation which is used.

In the next section, the Committee looks at long-term planning before providing an overview of the demographic data which will govern the placement of NSW school facilities in the future.

1.6 Long Range Planning Issues

Long range planning projections are used by all NSW government agencies to ensure timely infrastructure provision.

While each agency undertakes its own demographic analysis to determine when and where to build its public facilities, the need for a 'whole-of-government' approach to major urban

developments or redevelopments adds an extra degree of potential difficulty to the planning and funding process.

The Committee has consistently sought evidence of the level of cooperation between government agencies in its inquiries.

The provision on school facilities in NSW is no different to any other type of public infrastructure. The DSE must work within a planning system directed by government policy and involving input from multiple agencies. Often, there are competing agendas and competing demands within individual agency budgets which may affect the time frame for the delivery of necessary infrastructure.

This is a particular problem in new urban growth areas where long-term commitment by all government agencies must be backed by sufficient ongoing funding streams. Ensuring that funding is available at the right time requires careful planning from all agencies involved. It is pointless to provide schools without roads, sewerage, electricity or hospitals.

Planning matters of State significance in New South Wales are the responsibility of the Minister for Urban Affairs and Planning under the Environmental Planning and Assessment Act 1979.

Planning in metropolitan regions is governed by the principles of Integrated Urban Management, which are embodied in *Cities for the 21st Century*. This document advocates a whole-of-government approach to strategic planning based on four goals: equity of opportunity; resource efficiency; environmental quality; and enhancing quality of life. The primary goal is to stop urban sprawl by achieving more compact and sustainable cities which take up less new land by getting more use out of existing urban areas and infrastructure.

Cities for the 21st Century estimated that approximately 640 000 new dwellings would be required in the Sydney region by 2021 and advocated two policies for their sustainable and compact delivery:

- Increasing the proportion of multi-unit dwelling forms to 65% by 2020, with a target of two-thirds built in established areas.
- Increasing the average dwelling density of new housing estates on greenfield sites to 15 dwellings per hectare by 2005.

In addition, major redevelopments such as City West, the corridor along the New Southern Railway, the Rhodes Peninsula and the Olympic Village will consolidate urban development within existing urban boundaries.

The DSE must balance its own planning imperatives with the additional requirements imposed by these large urban developments.

Formal planning for school facilities in NSW is based on a 3-5 year rolling plan, although the

development stage often begins much earlier for large scale projects such as the North-West Sector (Rouse Hill) of Sydney.

The Committee compared this system with that used in other countries, especially the US school system.

In the US school system, long range planning projections of up to 10 years are used with short term planning as a subsidiary of this extended cycle. Long term planning takes into account a broad range of issues including projected demographics of the community, forecasts of financial resources and strategies for the utilization of existing facilities. Assessments of the various costs of building options are built into the planning phase. Financial advice is sought from private companies and the most commercially competitive funding strategies are employed.

This extended time-frame enables planners and architects to select sites well in advance and take preliminary steps to secure sites for the future construction of school facilities. Such information also allows for the planning and construction of appropriate surrounding infrastructure as well as thoughtful implementation of educational innovations.

The long range focus also assists schools in the US to focus singularly on technological developments and build high levels of “flexibility”, “adaptability” and “modifiability” into planning. Plotting future technological trends enables a longer life cycle for buildings and facilities.

The Committee has explored overall planning issues with representatives of the DSE since May 1996, when departmental officers appeared before the Committee’s ongoing Inquiry into Development and Approval Processes for NSW Capital Works.

At the May 1996 hearing, Mr David Rowland DSE Director of Properties outlined the strategic planning process for school facilities:

School buildings operate on a lead time of several years. We talk of a three to five year rolling plan. We put three years of priorities towards Treasury each year when we submit budgets. Our own studies look quite a bit further ahead than that, particularly with the release of new urban areas. We buy sites by requirement under the Environmental Planning and Assessment Act. Frequently, we will buy those five to 10 years ahead of actually building the schools because we need to acquire those sites earlier than the commencement of housing development, rather than trying to acquire sites once the area is covered with houses.²

The Committee has already summarised this planning process used by the DSE in Section 1.2 of this Report.

² NSW Standing Committee on Public Works, *First Report on Development and Approval Processes for NSW Capital Works* (Report No.2, 1996), p.59. (In later footnotes, this Report is abbreviated as “SCPW, Report No.2”)

In addition to the utilisation of forward planning techniques to deliver schools to new urban areas, Mr Rowland noted that the DSE must consider the way in which demographic movements shift need and amend its resource allocations accordingly:

The acquisition of new property is primarily driven by demography. One demographic problem for the department is that its numbers are not growing significantly, but they are moving significantly. New suburbs develop, old suburbs age, and this creates a resource distribution problem. No one in the old suburbs wants the department to close schools, yet new suburbs demand the provision of school resources—not only demand but require resources because the department cannot cope with the increase in demand in absolute terms.³

The Committee returned to this issue in its public hearing for this inquiry in February 1997. Mr Rowland was questioned by the Committee about problems in the longer term planning process:

CHAIRMAN: The Department of School of Education prepares its capital works program on the base of a three- to five-year rolling plan. What longer term planning occurs?

Mr ROWLAND: It is very hard to systematise that. It is difficult to be substantial even with three years when you are operating to annual budgets in about the third year. Long-term planning is a real difficulty. However, long-term planning is based on broad demographic projections and rates of development and is most clearly reflected in the strategy we have for acquiring sites. Wherever planned developments occur, we are part of the consent process and the process that develops overall scenarios for rates of development, likely populations, likely school populations, and locations for school sites within the development of the plan. Under the Environmental Planning and Assessment Act we are required to identify and acquire those sites once they are appropriately zoned should the landowners wish us to acquire them in advance of the actual need. That represents a major part of our business with all the major urban developments in New South Wales. Smaller country developments are less predictable, less planned and much more responsive to local circumstance. Because school populations usually do not double overnight in large numbers we can respond using relocatable buildings and develop our plans as we see the picture emerging. (2)

In this evidence, Mr Rowland reiterated the importance of demographic projections and a holistic planning process within government in enabling the DSE to purchase sites and plan the development of school facilities.

The Committee also questioned Mr John Zahn of the DPWS about the point at which his

³ SCPW, Report No.2, p.59.

department became involved in the planning process under the terms of the Working Agreement between the two departments:

Mrs BEAMER: The Department of School Education prepares its capital works program on the basis of a three- to five-year rolling plan. When does the Department of Public Works and Services become involved in the capital works process?

Mr ZAHN: We actually have some involvement up front, early in the piece, as far as advising the DSE on the potential costs of any site. The process in place at the moment is a precise science in some ways; it has a precise set of documents and precise codes. Therefore if the DSE knows the size of the school it wants we can give it a quick prediction of how much it will cost today, next year and the following year. The Treasury bid is based on our advice for the final cost with cash flow predictions for the work, if it is approved.

Mrs BEAMER: Do you become involved in strategic planning?

Mr ZAHN: No.

Mr Zahn indicated that the DPWS is actively involved in the preliminary planning process, advising on the implications of site selection including its required size and the cost of facilities. The DPWS provides the data which is submitted to Treasury as part of the DSE capital works program.

The Committee also ascertained that the DPWS ensures that school facilities meet government asset guidelines and building codes:

Mrs BEAMER: Does the Department of Public Works and Services review the viability of proposed works with the Department of School Education in terms of total asset management?

Mr ZAHN: That is our role for government as well. We have to advise all our clients, not just the DSE, if something is outside the total asset management procedures. Again, because schools are well regulated so far as the codes, requirements, specification guides and the way that contracts are set up, the situation hardly ever occurs in which a decision is needed on how far we should go with it. It is quite easy; it is all set up. It is not as if it is a one-off project each time. The only time that situation would occur is with a major upgrade taking place. We would have to work out how far we go. Again, the codes form the basis of how we actually make decisions. There is no special code for Rose Bay versus Broken Hill: the code takes precedence over wherever we go in the State. (48)

Mr Zahn noted in evidence (52-3) that the new NSW High School Facilities Standards - developed by the DPWS and the DSE - had been taken up by the Commonwealth Government to assist in determining funding levels for non-government schools throughout Australia.

The first high school in Australia to be built according to the new Facilities Standards - at Glenmore Park in Western Sydney - has gone to tender and funding of \$2 million has been provided for Stage 2 in the 1997-98 NSW Budget.

Mr Zahn stated that the new Facilities Standards had incorporated some structural design changes which would enhance the utility of school assets:

We have reduced the number of specialist spaces; we have built workshops and beside each workshop are two parallel classrooms. If the workshop is to be used for art, those teachers do not own the two classrooms beside it. There is a lot more flexibility for services, it is a lot more modern, and it is a better way of using a high school. The school could change the workshop around. If a new principal and new staff do not want to do art, they can change the workshop to a radio station or a drama room. The whole school will be built like this once we get approval to let the tender. A lot of people have heard about it and would like to get their hands on this document. It is a very interesting way of building a school. (53)

The Committee believes that the current planning system employed by the DSE will meet the current and projected needs of the NSW education system and is supportive of a 'whole-of-government' approach to development. It is satisfied that the DSE planning process measures up to international standards, particularly its US counterpart.

The Committee is also impressed by recent innovations by the DSE and the DPWS.

The new Asset Management System will give the DSE a comprehensive database of all NSW school facilities for the first time.

In tandem with the new Schools Facilities Standards, this will present the DSE with a clear picture of infrastructure shortfalls.

The new Schools Facilities Standards are the product of close and critical analysis of existing school assets by the DSE and the DPWS.

The Committee congratulates the DSE and the DPWS on developing these state-of-the-art Schools Facilities Standards, which will be used by the Commonwealth Government as the national standard for determining the requisite level of school facilities.

The School Facilities Standards will help promote educational equity across the regions of NSW and ensure a streamlined development and approval process for capital works projects.

One area of interest for the Committee was the DSE's methods of collaborating with other government agencies in planning the urban face of NSW in the 21st century.

The Committee investigated two aspects of this process:

- **The delivery of schools to growth areas through the Urban Development Program (UDP).**
- **The upgrading of existing schools to meet the requirements of areas earmarked for urban regeneration as well as the related issue of asset realisation.**

Providing school facilities as part of each of these programs depends on timely and accurate demographic forecasts as well as good coordination between government agencies.

In new urban growth areas, the DSE works with other planning authorities to plot the staged delivery of schools in tandem with other government services. In areas identified for regeneration, the DSE either renews existing schools or must find new sites in sometimes crowded inner city areas.

The Committee looks at both these issues in the next two sub-sections of this Report.

1.6.1 The Urban Development Program (UDP)

The Sydney Region Urban Development Program (UDP) is the principal tool for determining and delivering new urban growth areas for metropolitan New South Wales.

The UDP is a government land release system in Sydney and the Central Coast designed to ensure sufficient supply of new residential sites. Land is selected by the Urban Policy Committee of Cabinet and the UDP is managed by the Department of Urban Affairs and Planning (DUAP). There are local UDPs for Newcastle and Wollongong.

The UDP is prepared for the following five-year period within the framework of the metropolitan strategy. It provides a development schedule for each Local Government Area (LGA) selected for urban growth in that period. The UDP currently covers 90 release areas in 14 LGAs. The most recent UDP program was for the years 1995-96 to 1999-2000.

Land is included in the UDP prior to rezoning for urban purposes so that planning and servicing can be coordinated to enable timely lot production. It also provides a focus for decisions on future land uses and infrastructure planning. The UDP considers issues such as economic feasibility, environmental impact, urban capacity and service provision and includes forecasts of land development, housing demand, planning and servicing in 82 release areas in Sydney's outer areas over a range of price categories and locations.

The current parameters of the UDP will accommodate Sydney's greenfield estate housing needs until approximately 2005-2010.

In the longer term, options include extensions to Rouse Hill and Warnervale and the South Creek Valley sector beyond the proposed Sydney West Airport. The Committee considered proposals for urban development in South Creek Valley as part of its report into State Infrastructure

Requirements for Sydney West Airport (Report No.1, 1995).

In evidence before the Committee for its Inquiry into Development and Approval Processes for NSW Capital Works in 1996, Mr Rowland outlined the role of the DSE in this urban development planning process:

... we must serve the urban development plan of government. The Department of Urban Affairs and Planning sets the lead for us. We are part of that planning process. We are a consent body involved in the early days of development of local environmental plans. We are required under the Environment Protection and Assessment Act to acquire property, as it becomes available, for the provision of schools. That process has long lead times but it is relatively straightforward, provided that family size stays reasonably constant.⁴

The DUAP is the principal body for coordinating infrastructure provision to new urban growth areas. The DSE responds to the UDP by acquiring sites and organising related infrastructure such as road access.

The Committee examined the issue of site acquisition in the current inquiry.

Mr Rowland of the DSE provided examples of the site acquisition program, such as the North-West Sector development:

From the early stages of any planned development School Education is one of the first authorities consulted and asked to identify its requirements. For example, with big developments such as the north-west sector or the west Liverpool developments. We identified our requirements in the North West Sector in about 1988. So far we have acquired three of approximately 20 sites and have built one school. You can see that lead times are quite lengthy. (2)

Mr Zahn of the DPWS also cited the North-West Sector during evidence as an example of the problems faced by government agencies when populations predictions were not reached:

It is difficult to be accurate with demographics because they change so frequently. Five years ago everyone said that the North West Sector of Sydney was going to blast off, that we would need 16 high schools and so on. We have put in only one primary school there and they have filled in only one side of the development—it has not taken off. DSE had a holding school—an existing primary school beside it—that was only demountables. It was a poor location and they were never going to keep it, but they kept it as a holding school, waiting for the houses to build up enough demand, then we built the new school beside it. Quakers Hill east is another example. There was an

⁴ SCPW, Report No.2, p.60

existing school for a long time and we developed around it. (59)

The Committee questioned Mr Rowland about the manner in which site acquisition raised community expectations about the future construction of schools and may even have dictated where people purchased their homes.

Mr Rowland conceded that there was always the possibility that urban developments may not proceed at planned rates, thereby reducing the need for more schools:

CHAIRMAN: One question that arises with new developments, including Landcom developments, is that a site might be acquired or designated for a school at a later time and people believe some type of warranty is given that a school will be at a particular location when they purchase land. It is not the responsibility of the Department of School Education, but can you think of ways to overcome that problem?

Mr ROWLAND: We have taken some pains to address that problem over the past four or five years, essentially by being careful in our studies. We can only be as good as the quality of the study and the information that we have. We will not raise expectations if it is not appropriate to supply a school. One problem is that the number of children in new housing developments has declined over the last 20 or so years. People who were making predictions 20 years ago for a school that may have been built 10 years ago, or people who were making predictions 15 years ago for a school that may have been built five years ago, may have found that the picture changed quite dramatically in the intervening years. Perhaps one in four of the schools that they had planned is no longer needed. (4-5)

Mr Rowland noted that the DSE was in a difficult position in new urban growth areas where temporary enrolment surges were predicted.

The DSE had to decide whether to build schools which could be downsized in the future - through the use of demountable buildings - or to build too many schools and then close entire schools as numbers dropped:

We have two choices: either plan and run the schools for large numbers during the years of peak enrolment and let them decline over time so that in about 20 years after the commencement of the school building program they will be comfortably matched to the student population and remain so for many years; or build an excess number of schools and remove some from the stock as the student population declines. Unfortunately, that involves social problems such as communities resisting the closure of schools. The communities like their schools and say that the department should not take them away. For the moment we have opted to go down the path of maintaining the number of permanent schools only—not close schools—and have fairly large schools with

a fair amount of relocatable accommodation during years of peak enrolment.
(5)

Proposed stages of development and population settlement for the North-West Sector of Sydney have not been reached, leaving government agencies such as the DSE with designated sites that are not being utilised.

Coordinating and timing urban development in NSW will be enhanced by the establishment of the Urban Management Committee of Cabinet (UMCC) and the Ministry of Urban Infrastructure Management.

The Committee will examine the UMCC as a possible solution to infrastructure timing and coordination problems in greater detail later in this chapter.

1.6.2 Urban Regeneration

The current NSW Government has been promoting urban regeneration - or urban infill as it is also known - as a possible remedy for the social, environmental and economic strains created by continuous urban sprawl in NSW.

Clearly, increasing population densities in established areas through higher housing densities will maximise the use of existing infrastructure. It may also be more economical to upgrade existing infrastructure rather than provide new infrastructure to growth areas.

However, there are difficulties for a department such as the DSE in planning services for areas of urban regeneration.

Urban regeneration may deliver significant population increases to a region but there is no guarantee that this will significantly increase the school age population and, therefore, the pressure on existing school facilities. It may be that a demographic breakdown of this increased urban population shows that there is an insignificant component with school age children.

The Committee's *First Report on Development and Approval Processes for NSW Capital Works* scrutinised the strategic planning processes of a number of NSW government departments including the DSE. During the public hearing for that Report, Mr Rowland raised the problem of providing services to areas of urban renewal:

We do have a looming problem, I believe, in urban renewal. The forces of government planning, economy and everything else are gradually leading to the renewal of inner suburbs high-density housing. Schools such as Strathfield South that we are currently upgrading back up to big numbers. Campsie is back up to big numbers. Recently we reopened classroom spaces around Glebe and we expect to do it on the Balmain peninsula in the near future, even though there is surplus capacity there now, because of the redevelopment of industrial areas for housing. It is with some care that the department considers closures of schools and getting

right out, because you cannot get back in.⁵

The Committee returned to this issue during its hearings for the current inquiry.

In evidence, Mr Rowland outlined the manner in which the policy of urban regeneration was beginning to influence DSE planning decisions:

In some urban areas the broad strategies of increasing density are beginning to have a significant impact on old schools; because the old schools are there the capacity exists to renew and regenerate them. The old schools can be modernised and serve a renewed young population. That is identifiable in the ring around Sydney: we have reopened an old building at Glebe Public School, we have refurbished Birchgrove primary school on the Balmain peninsula and we expect to do some work in the surrounding schools. We have just finished refurbishing Strathfield South primary school, which is surrounded by a large number of home units and has a high young population. Many examples of that kind can be given. (5)

The lack of a coordinated planning strategy for urban renewal was outlined by Mr Rowland in evidence:

I know of no uniform overall planned urban strategy that says that a particular area will renew at a particular rate and that the population can be expected to increase at a certain rate, so that we can plan well in advance. In Sydney there are areas where some school accommodation is badly underutilised. The question is whether or not some schools should be disposed of by closure or whether they should be held against increasing densities over the next 20 years. We do not have good evidence to go one way or the other on that. (5)

Mr Rowland reiterated the difficulty of obtaining accurate demographic data to predict the size and composition of urban regeneration:

Mr SULLIVAN: With regard to compact cities and urban regeneration, is there a strategy adopted by the Department of School Education in terms of existing stock and the need for additional acquisition?

Mr ROWLAND: As yet we do not have good empirical data to back our planning decisions. In my role as Director of Properties I say that that is based in part on some emerging studies, in part on anecdotal evidence and in part on my administrative instinct. (5)

Mr Zahn of the DPWS also indicated in evidence that accurate demographic forecasting was essential in predicting enrolment upswings:

⁵ SCPW, Report No.2.

It is demographics. Mr Rowland mentioned Strathfield South, which is an inner-city area. We have just finished renovating that in a major way because we had an influx of population. It is a demographer's job to predict the trends—if it is a transient area, a stable area.(59)

A particular problem investigated by the Committee was premature realisation of government assets in areas subsequently earmarked for urban regeneration, which has resulted in costly and difficult identification and purchase of new sites.

Mr Rowland outlined the problems which had emerged in Victoria as a result of the current Government's program of asset realisation being followed by urban regeneration and renewed pressure for school sites. Mr Rowland explained that the NSW Government followed a cautious approach to asset realisation based on this experience:

I remain reasonably cautious on the question of simply disposing of any unwanted capacity; I prefer to find other uses. It may well be that broader policies will dictate what will happen. I understand that in some areas in Melbourne which have had similar problems with school closures already some regret has started to emerge that perhaps a few too many schools went, with renewals occurring and sites being redeveloped. We walk the line between how much of the old stock should be kept and how much should be disposed of: it is a difficult issue. (5)

The Committee supports the concept of urban regeneration as part of a coordinated strategy to control Sydney's urban expansion.

The Committee is concerned about the level to which a whole-of-government approach has been taken in the past to planning urban renewal.

Strategic planning for individual departments - such as the DSE - has been hampered by planning changes.

For example, the DSE realised assets in Pyrmont in the 1980s because of low enrolment levels only to be forced to find new sites for schools as population increased with urban regeneration. Pyrmont had been earmarked for mainly industrial redevelopment at the time that the school sites were sold.

Similarly, the Victorian Government's fire sale of government assets in recent years has been counterproductive in the long term because government agencies are now being forced to find and acquire new sites in the revived inner city suburbs of Melbourne.

Clearly, a cautious approach to the realisation of assets is therefore warranted.

Areas - and their schools - can enjoy a renaissance. For example, high schools in Balmain

and Glebe in inner Sydney have been enrolment ‘underachievers’ in recent years. However, the regeneration of these areas with high density housing means that it was worthwhile persevering with these schools through demographic lags in enrolment.

The ability to gain some commercial return from under-utilised assets is the key to justifying their retention in the short to medium term. This will provide a revenue stream while maintaining flexibility for the future. Such strategies could include leasing assets to private enterprise and community groups.

The unpredictable nature of demographic movement as well as changing planning policies and priorities means that the DSE is wise to pursue a cautious policy to asset realisation.

It is clear to the Committee that a holistic approach to planning is required at the highest political level.

In the next sub-section, the Committee examines the new Urban Management Committee of Cabinet as a possible solution to the historical problems of coordinating planning and infrastructure provision.

1.6.3 The Urban Management Committee of Cabinet

The current system for planning infrastructure provision in urban regions of New South Wales is being revised by the creation of a new Cabinet Committee to coordinate a whole-of-government approach.

The Urban Management Committee of Cabinet aims to improve the planning, delivery and maintenance of infrastructure in the Greater Metropolitan Region of Sydney, Newcastle and Wollongong.

The Minister for Education will be a member of this Cabinet Committee and this will strengthen the role of the DSE in the planning process.

The Urban Management Committee of Cabinet is responsible for the strategic assessment of new urban infrastructure. Its initial membership comprises:

- the Minister for Urban Affairs and Planning (Chairman).
- the Deputy Premier and Minister for Health.
- the Treasurer and Minister for State and Regional Development.
- the Minister for Transport.
- the Minister for Education and Training.
- the Minister for the Environment.
- the Minister for Community Services.
- the Minister for Roads and Minister for Public Works and Services.
- the Minister for Local Government.

This Cabinet Committee brings together ministers with responsibility for most infrastructure delivery in NSW with ministers who look after the welfare of the environment and the community at large.

Its initial work will be to develop an Urban Infrastructure Management Plan (UIMP) which will outline future metropolitan infrastructure needs.

The UIMP will cover a five year period and be updated and published annually. It is designed to ensure coordinated delivery of roads, water systems, open spaces, railways, housing, health and education services.

The UIMP will determine:

- Total infrastructure needs of the Greater Metropolitan Region over the medium term.
- Responsibility of each individual department and agency for infrastructure provision.
- Alternative ways of delivering infrastructure to Government agency provision.
- The method for translating these alternatives into actual projects with summaries of cost-benefit analyses and socio-economic studies to be completed.
- Cost estimates for projects (where possible).
- Projected sources of funding for individual infrastructure projects including joint venture with the private sector.

The UIMP will assist the Urban Management Committee of Cabinet to identify priorities for expenditure on major urban infrastructure projects.

The first UIMP is due to be completed during 1997.

The Cabinet Committee is to be served by the new Ministry for Urban Infrastructure Management (MUIM), which was established on 20 December 1996.

The MUIM will coordinate and integrate infrastructure planning and expenditure in the Region by establishing clear linkages between:

- Urban management strategies, which are coordinated by the DUAP.
- Infrastructure planning and provision, which is undertaken by individual government departments (often in conjunction with the DPWS).
- The budgetary process, which is managed by Treasury.

The MUIM has recently completed a consultation process to identify key infrastructure issues for the Greater Metropolitan Regions of NSW which included meetings at Blacktown, Liverpool, Newcastle and Wollongong.

The main areas covered were economic development, transport, housing, the environment and human services. The following issues were identified:

- The need for clearer priorities and greater choice in transport, particularly for developing areas.
- The lack of a whole-of-government approach to consolidate existing tools into a single, integrated mechanism.
- Earlier consideration in the planning process of environment and other significant community concerns.
- Greater coordination between government, community and the private sector in the provision of human services.

The MUIM is currently providing technical advice to the NSW Government's Waterways Advisory Panel, which is assessing a proposal by Sydney Water to improve water quality in Sydney harbour by the time of the 2000 Olympics.

The Committee welcomed this new strategy for ensuring timely and targeted infrastructure delivery for NSW metropolitan regions in the *First Report on Development and Approval Processes for NSW Capital Works* (Report No.2).

The Committee envisaged a constructive role for itself in this process, establishing contact with the MUIM, reviewing the UIMP process and providing a crucial forum for community consultation.

Recommendation 1 of Report No.2 by the Committee stated:

The Minister for Urban Affairs and Planning work with the Committee to establish systems which will ensure a constructive role for the Committee in the development and monitoring of the Urban Infrastructure Management Plan.

The Committee reiterates its recommendation from Report No.2 which welcomed the establishment of the Urban Management Committee of Cabinet to prepare an Urban Infrastructure Management Plan for NSW.

This body will provide the opportunity for a permanent solution to difficulties with the coordination, scale, timing and funding of infrastructure for metropolitan NSW.

However, the Committee is concerned that regional NSW should not be neglected in the push to improve urban infrastructure delivery.

The specific problems and needs of regional communities have been highlighted in recent years because of the closure of services, the rural economic recession and sustained adverse climatic conditions.

The provision of school facilities is a classic example of the need to maintain equity between city and country.

Children in regional NSW must be given access to high standard facilities in a quality education system which will provide them with a basis for further education and employment opportunities.

The Committee will continue to maintain a focus on regional NSW in its inquiries to ensure that regional communities reap the full benefit of valuable government spending on infrastructure projects.

This means focusing on both the equitable distribution of infrastructure around NSW and the method of its delivery to regional communities.

Local companies and subcontractors must be given the opportunity to tender for government public works projects on a level-playing field. Successful tendering by local companies boosts the local economy, provides patronage for local small business and skills the local workforce. This, in turn, reduces population drift to urban centres.

The Committee will continue to question government agencies that appear before it on strategies to enhance opportunities for regional companies to compete for infrastructure projects.

In the next sub-section, the Committee analyses demographic trends in NSW to determine the likely distribution of school facilities in the future.

1.7 Current and Projected NSW Demographic Patterns

Forecasted demographic configurations are used in association with community and expert consultation to determine the balance of school facilities in NSW.

Consistency of approach by the DSE enables the process for planning and constructing new or additional school facilities to involve a fairly standardised sequence of decisions and procedures. In this way, all proposed school developments can be evaluated by the DSE from a common point of analysis to ensure an equitable allocation of resources.

Demographic forecasts are affected by such issues as oscillating enrolment patterns, curriculum changes, funding restrictions and changing policy agendas. However, it is crucial that the provision of school facilities does not become a statistical game which disregards the wishes of the local community. Hasty analysis and insufficient community consultation can lead to ineffective demand assessment, unmet school accommodation requirements and duplication. This, in turn, seriously affects educational programs.

The Working Agreement between the DSE and the DPWS clearly delineates the respective roles

of the departments in an effort to reduce any duplication of resources. Before any planning for a new school, the DSE undertakes preparatory “needs and requirements” research. This research is conducted using statistical information provided from demographical databases and undertaking discussions with local planners, the local community and local school principals. It includes such simple tests as monitoring building applications by local councils to pinpoint areas of potential need.

There are many demographic issues which impact on school enrolments and the utilisation of existing school facilities. In particular, population shifts between and within regions of New South Wales and the States of Australia combine with changing immigration levels and balances to alter the demographic profile of NSW.

Demographical data has shown that the need to generate new student places in NSW schools is primarily the result of three factors:

- Student migrations between government and non-government schools.
- Shifts from established urban to newly developed areas.
- Movements from primary to secondary levels of education.

To accommodate the needs of a fluctuating and mobile population it is important to ensure that schools of the right size are located in the right place at the right time. This can entail complex problems of planning and organisation in which solutions are not always self evident.

Detailed and often complex demographic projection and planning techniques are required to ensure the most effective, efficient and flexible arrangements. By using the latest available demographical data covering all aspects of projected and current population growth, population movement and intrastate, interstate and overseas migration, the DSE can determine which areas will require new or upgraded school facilities.

Demography is also essential for the successful implementation of the Core Plus system, which utilises demountable accommodation to meet the temporary needs of schools with growing enrolments.

The Auditor General identified the difficulty in the use of demographic data in the *Performance Audit Report into the Department of School Education’s Effective Utilisation of School Facilities*. This report noted that over a ten year period to 1995, primary school enrolments increased by 3.4% while secondary enrolments decreased by 1.1%. Over the same period, however, regional variations ranged from a fall in primary and secondary enrolments of 9 073 students (-8.9%) in the metropolitan east region to an increase of 12 264 students (+24.1%) in the north coast region.⁶

⁶ Auditor General’s Department: *Performance Audit Report into the Department of Education’s Effective Utilisation of School Facilities*, September 1995

Table 3 provides an overview of the changes in enrolments by region in NSW over the past ten years.

TABLE 3: Changes in Enrolments by NSW Region

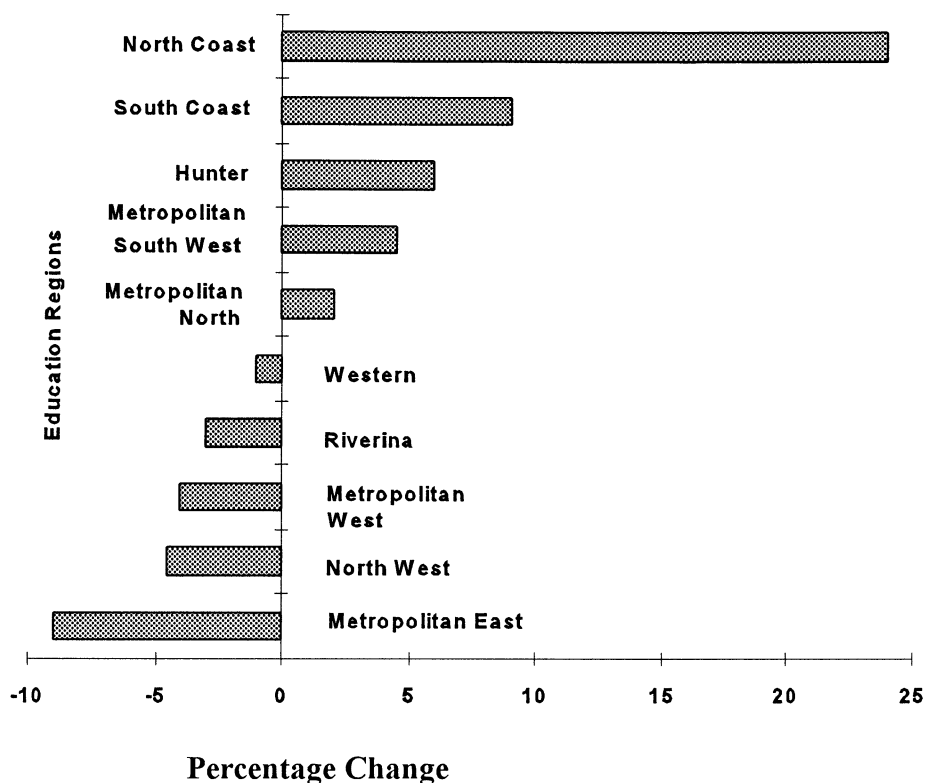

Source: Auditor General's Department, *Performance Audit into the Department of Education Utilisation of School Facilities* (1995), p.17.

In the past, the various DSE regions conducted their own demographic research and analysis. The restructuring and re-centralisation of the DSE in 1995 complements this system by introducing a new capacity for overview which will ensure the equitable distribution of resources.

In evidence before the Committee on 13 May 1996 for its Inquiry into Development and Approval Processes for NSW Capital Works, Mr Rowland was questioned about the impacts of this change in the DSE's information-gathering procedures:

CHAIRMAN: You mentioned demographic analysis. How is that arranged in the department at present?

Mr ROWLAND: We have our own expert demographers.

CHAIRMAN: Are they regionally based?

Mr ROWLAND: They were regionally based but the restructuring has made them centrally based. That is taking effect now. We had one in all the growth regions and part of one in the Riverina region where there is little growth. We will do some of that in

house. We will probably have to contract some of the major studies out but that is the nature of the work at the moment. We are just feeling our way into that. Demography is very important in the department. We run a continuous record of all schools back five years and up five years and we update that so that we have a good overall working picture at all times.⁷

In the rest of this section, the Committee will outline recent demographic trends which have had an impact on the operation of the NSW education system and which will continue to determine the distribution of school facilities in the future.

1.7.1 Population Size, Distribution and Age

Effective educational planning requires an in-depth and realistic assessment of the particular context within which the DSE operates both now and in the medium to long term. A critical aspect of this assessment is the monitoring of past, present and future population patterns.

According to the report, *Implications for School Education*, prepared by the Department of School Education Planning Unit in June 1993, the NSW population grew by an estimated 1.1% in the 12 months to September 1992 after averaging 1.2% annual growth between 1986 and 1991. The Australian Bureau of Statistics (ABS) reports that population growth is expected to increase between 1995 and 2011 by up to 19% if fertility rates are maintained and interstate migration remains constant.

However, rudimentary analysis of population changes in NSW provides a poor measure of likely school enrolment levels on its own. There is no causal relationship between changes in the total population of a region and changes in school enrolments.

In order to effectively respond to this burgeoning population, the DSE utilises in-house demographers to focus on those trends which have a direct bearing on enrolments and hence school facility requirements.

By using demographic trends such as fertility rates, movement between government and non-government schools and the population age structure, a more relevant gauge can be developed to forecast future enrolment patterns.

The effects of the age structure of the NSW population will have the greatest impact on future school enrolment levels.

An aging population is the dominant demographic trend in Australia. It is the outcome of sustained falls in fertility rates caused by the trend towards later marriage and deferred childbirth as well as increased longevity and falling mortality rates. As this trend continues, school aged children will comprise a shrinking proportion of the population.

⁷ SCPW, Report No.2, p.66-7.

1.7.2 School Enrolments

The number of school aged children in NSW is subject to cyclical variations despite overall population growth. Regional variations in population distribution also affect the location of school facilities.

Implications for School Education (1993) provides data on the regional age structure of the NSW population. In 1986, the proportion of the total population aged between 5-19 was 23%. It is predicted that this group will constitute only 18% of the total population in the year 2021.

Table 4 shows enrolments for NSW government school 1950-1990 and a projection for 2002.

TABLE 4: Student Enrolments 1950-2002

Year	Enrolment Nos
1950	385 303
1978	812 000
1990	743 000
2002 (projected)	775 000

Due to its relatively larger population, the greatest increase in absolute numbers of students to 2002 will occur in Sydney. However, Sydney's rate of growth in student enrolments will be half that of the Illawarra and South Eastern divisions (which together closely approximate the DSE South Coast Region) and only one fifth of the growth rate of the North Coast.

Table 5 outlines the anticipated growth rates in the statistical divisions of NSW for the 5-19 year age group and for the total population for the period 1991-2001.

TABLE 5: Projected Population Change 1991-2001, NSW Statistical Divisions

Statistical Division	Number		Per Cent	
	Age 5-19	Total Pop	Age 5-19	Total Pop
Sydney	+69 200	+1 152 440	+8.59	+31.18
North Coast	+43 100	+329 820	+47.37	+78.01
Illawarra	+13 080	+120 000	+17.19	+34.94
South Eastern	+6 480	+76 110	+17.47	+44.94
Far Western	-2 680	-9 030	-51.05	-36.12
Murray	-3 620	+21 300	-14.42	+19.24
Orana	-3 920	+3 760	-14.64	+3.31
Hunter	-5 190	+89 820	-4.61	+17.39
New England	-7 100	+15 820	-15.83	+8.56
Central Western	-9 520	-3 960	-24.29	-2.35
Riverina	-10 830	-9 950	-31.69	-6.87
TOTAL NSW	+89 000	+1 786 130	+6.86	+30.30

Analysis of this data enables demographers to predict that growth in the 5-19 years age group will be limited to the Sydney (8.59), North Coast (47.37%), Illawarra (17.19%) and South Eastern (17.47%) regions. Subsequently, these regions will also experience the largest increases in school enrolments.

All other regions will experience a reduction in the 5-19 years age group and hence the number of school-aged children. The Riverina (-31.69%) and Central Western (-24.29%) regions will record the largest decline in the 5-19 years age group of all the statistical regions in NSW.

In the Murray, Orana, Hunter and New England regions, a significant drop in the 5-19 years age group is expected even though the total population will increase. Of these regions, the Hunter records the most significant variation between the 5-19 years age group (-5 190) and the total population (+89 820).

1.7.3 Fertility Rates

Generally, birth rates are fairly stable although rises in birth rates do occur which produce a bulge in the age profile of school students.

Primary school enrolments are now dominated by the flow-on effects of the uneven rises in birth rates during the 1980s. Fertility rates reached a peak period in 1971-72 with 97 435 births and began to drop from 1980-81 to a range between approximately 81 000 and 87 000 births. They have stabilised at the high end of the 80 000 range.

Fertility rates vary widely from region to region. Fertility rates for the under 20's age group in the statistical subdivisions of Fairfield-Liverpool, Outer South Western, Outer Western, and Blacktown/Baulkham Hills are more than seven times higher than that for the same group in the Hornsby/Ku-ring-gai area.

The combination of high fertility rates and a young population produces high crude birth rates. Campbelltown (19.1 per 1000), Hawkesbury (18.9 per 1,000), Blacktown (18.5 per 1,000) and Penrith (18.4 per 1,000) have the highest crude birth rates of metropolitan Sydney. These regions have also been identified as major growth areas in NSW. The highest birth rates in country areas are found predominantly in Western NSW areas - Bourke (28.2 per 1 000 people), Murrumbidgee (27.4 per 1 000) and Brewarrina (23.7 per 1 000). However, these regions are consistently losing population to other areas of NSW.

If high crude birth rates occur concurrently with increases in total population, the DSE is able to accurately predict that school enrolments for kindergarten, for example, will increase by a certain amount in a certain year. If high crude birth rates occur concurrently with decreases in total population, the DSE is able to predict that school sizes will either remain stable or be reduced.

1.7.4 Intrastate Migration

Intrastate migration is especially influential in the DSE's planning of new schools in NSW. The

increased mobility of the NSW population has resulted in significant regional variations in the number of school aged students attending NSW government schools. Table 6 provides a detailed picture of migration flows between different areas of NSW.

TABLE 6: INTRASTATE MIGRATION NSW, 1981-1986

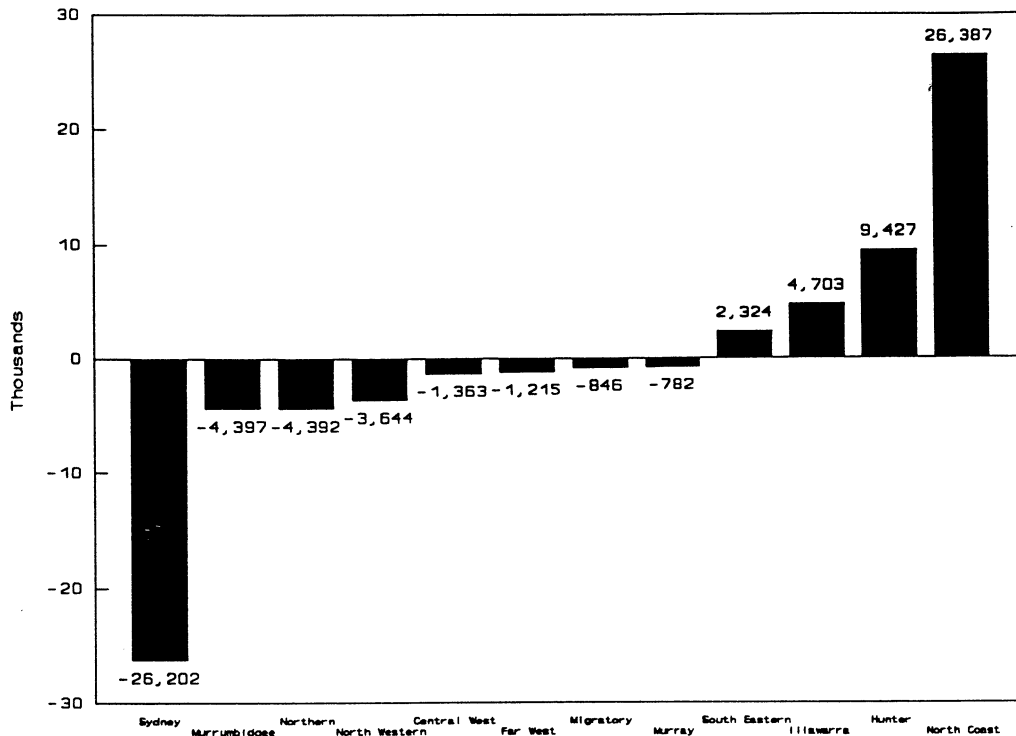

Table 6 indicates that the overall migration pattern in NSW is from inland areas to coastal areas and to the north along the coast.

Net intrastate migration is most pronounced on the North Coast of NSW.

For the period 1981 and 1986, Sydney experienced the largest loss of people (26 202), a high proportion of whom moved to the North Coast region (17 076).

Of all NSW regions, the North Coast had the highest net immigration gain (26 387). On the whole intrastate migration was responsible for 62% of population growth on the North Coast.⁸

The DSE has anticipated from analysis of the demographic trends, that substantial increases will occur in enrolments in Western and South Western Sydney, the Central Coast, the South Coast

⁸ NSW Department of School Education, *Recent Demographic Trends in NSW - Implications for School Education*, 1993.

and the North Coast. All other regions of NSW are predicted to either remain stable or experience decreases in enrolment levels.

Notwithstanding regional variations in population growth, birth rates, and intrastate migration the characteristic peaks and troughs of the current system are expected to continue.

1.8 School Asset Management in NSW

Comprehensive asset management is a key to the equitable provision of school infrastructure because it enables existing facilities to be fully utilised and new capital spending to be properly targeted. However, studies conducted by the National Board of Employment, Education and Training (NBEET) have suggested that the long range planning approach of school departments throughout Australia has been limited by incomplete asset registers.

The NSW Department of School Education has recently introduced a state-of-the-art asset management system.

It is obvious that school planners stand to benefit from a system in which the location and capacity of existing assets is readily available. This enables a high level of flexibility to respond to identified needs.

To provide maximum efficiency in the use of assets, planners should not only focus on “macro” level infrastructure indicators but should also be able to develop a “micro” profile of the capability of existing facilities in individual schools.

The Committee explains the merits and limitations of these concepts in the next sub-section before comparing its own model for judicious asset management with that recently introduced by the DSE.

1.8.1 The Concepts of Macro and Micro Planning

A macro approach has been the primary method of assessing school infrastructure needs in Australian schools to date.

The key characteristic of a macro approach to school infrastructure provision is the use of schedules which itemise facilities standards and detail the entitlements of schools of different enrolment sizes to general teaching spaces, specialist teaching areas and facilities such as libraries, gymnasiums and administration areas. These macro indicators - coupled with demographic projections of student enrolments - enable planners to estimate the required number of new student places and the level of refurbishment needed to upgrade existing facilities.

The macro approach identifies those schools with the greatest (enrolment based) need and those schools in which the difference between existing facilities and those of new schools are most marked. It is commonly referred to as the “deficiency” or “gap” approach because it focuses on resources that schools do not have, rather than the resources they do have.

Clearly, the macro approach has limitations. Firstly, it is based on the application of facilities standards which have steadily improved to an existing building stock of varying ages. This leads to the identification of large numbers of infrastructure needs which have little prospect of being met in the foreseeable future. Secondly, it tends to place schools in the position of passive recipients of infrastructure that is externally determined, thereby working against the benefits that can flow from greater school involvement in infrastructure planning and utilisation. Thirdly, it has difficulty in adapting to curriculum changes because it does not promote flexible use of existing resources. For example, the increased emphasis on technology learning in the NSW education system will invariably produce a need for more specialised teaching spaces. Without flexible use of existing facilities, new ones will have to be constructed at significant cost.

Alternately, the micro planning approach focuses on infrastructure capability at an individual level, providing school planners with more capacity to assess and realize the potential of existing school facilities. It derives from the schools' own experiences using innovative resource-use strategies to focus on the important relationship between infrastructure resources and desirable education outcomes.

It has been argued that a systematic assessment of infrastructure needs in Australian schools requires a coordinated approach using both these perspectives.

The Committee believes that the development of a comprehensive and flexible asset register is crucial to an integrated approach to infrastructure provision.

The DSE has been developing such a system for NSW.

In the next sub-section, the Committee outlines the features of a comprehensive asset management system.

1.8.2 The Features of a Comprehensive Asset Management System

A recent NBEET Report titled *Developing Indicators of Infrastructure Needs in Secondary Schools* (Report 31, August 1994) concluded that the asset registers maintained by the various State education departments around Australia were of limited use in determining the capability of existing school facilities because of their reliance on "macro" level indicators.

In order to make strategic decisions which meet contemporary needs and provide flexibility for the future, planners and architects require better information on the status of existing infrastructure and possible alternative uses.

NBEET believed that asset register systems should, in theory, be capable of complementing macro indicators by providing area measures classified in terms of general learning spaces, specialist teaching areas, and staff/student amenities. Asset registers should also, in theory, provide departments with information on the condition of assets.

It was noted by NBEET that although equipment registers were being added to asset registers,

they were not being integrated with building information. This reflected a limited use of asset registers primarily for accountability and maintenance purposes.

Further, the NBEET Report identified problems in the method used to compile asset registers. This resulted in insufficient information being recorded on the asset registers, especially on the usage of school facilities. For example, a technical workshop may be used for technical studies for only a few hours a week yet its scope for expanded use will not necessarily be recorded in the register.

The NBEET Report proposed that asset registers include information on the current use of space to determine where availability could be increased. Making greater use of existing infrastructure has a great impact on planning decisions for new or additional facilities.

The effective utilisation of existing school facilities has been already assessed in New South Wales by the Auditor-General in 1995.

In a Performance Audit Report titled *Effective Utilization of School Facilities*, the Auditor-General argued that school facilities in NSW were not being fully utilised and that this was resulting in the unnecessary construction of new infrastructure and additional management costs for existing assets. The Report contained a survey of 1 600 NSW schools which found that 87% of standard classrooms and 49% of specialist classrooms were fully used during the school day. The Auditor-General concluded that there were 258 classrooms (less than 1%) which were estimated not to be used at all and, in total, over 2 600 classrooms (approximately 6.5%) which were used for half of the school day or less. The Audit also found that 46% of primary schools and 65% of secondary schools surveyed considered that their school facilities were not fully utilized. The Auditor-General expressed concern that the DSE did not have targets or guidelines in place for the utilisation of surplus rooms and that no procedures existed to adjust funding to those schools where facilities were seriously under-utilised.

The Committee does not share all the Auditor-General's assertions.

The Committee agrees that asset registers should contain data on the capabilities of existing school infrastructure.

However, the Committee holds reservations about the ability of schools to increase their capabilities by focussing on the full utilisation of school facilities.

While the case may be made that better administrative organisation in schools may free-up some classrooms for alternate uses, it is apparent that these cases would be largely site-specific. A comprehensive review of utilisation of existing facilities would not result in a large-scale restructuring of school capabilities.

The Committee believes that while in theory the use of better asset registers may lead to the 'discovery' of some surplus school capacity (and hence increased infrastructure

capabilities), this space may be difficult to isolate and utilise in practice.

The Committee would be concerned if resources were directed towards squeezing more use out of existing facilities at the expense of the 'main game'.

The Committee is pleased to report that the DSE is committed to the equitable distribution of satisfactory facilities across all schools in NSW.

In the next sub-section, the Committee looks at the new asset management system being introduced by the DSE and how it will enable facilities shortfalls to be identified and addressed.

1.8.3 The Recent Implementation of a Comprehensive Asset Registration System in NSW

The previous sections of this Report have highlighted the fact that the establishment of a comprehensive asset register is essential to judicious asset management. For effective long range planning to occur, the DSE administration must know the number, status and condition of school facilities.

The DSE asset register and asset management system has been the focus of ongoing concern in recent years.

Most recently, the NSW Parliamentary Public Accounts Committee (PAC) expressed concern about inadequacies in the asset registration system in its report, *Matters Arising from the NSW Auditor-General's Report 1995* (Report No.11/51 - 1996). The PAC noted that the financial accounts of the DSE failed to identify the condition of individual assets, maintenance and refurbishment regimes, and the estimated economic lives of facilities. The PAC was particularly concerned about the poor quality of available data on the condition and value of the DSE asset base. The DSE conceded in evidence that its asset register was insufficient:

The problem the Department of School Education faced in endeavouring to value its assets and appropriate depreciations component was that it really did not have a very comprehensive and descriptive inventory of all its assets. It had assets by schools and by floor area but not by condition or method of construction. (PAC Report 11/51 - 18)

However, the DSE advised the PAC that a new asset management system was due to be introduced in April 1996:

The first phase of it comes on line next month (May 1996): an asset management system which will give us very accurate data on our sites; anything that affects those sites ... Within another 12 months we will be in a position where every school in NSW will have a very comprehensive graphical and written set of data. it will be the system on which asset management is carried out. We think that it is a fairly major achievement because it is a very large portfolio of property. (PAC

Report 11/51 - 18)

The new asset management system was designed to provide a comprehensive and descriptive inventory, which would improve the DSE's capacity to value its assets and establish an appropriate depreciation component in its financial accounts.

The Standing Committee on Public Works first raised this matter in 1996 during its Inquiry into Development and Approval Processes for NSW Capital Works when Mr Rowland of the DSE appeared to give evidence. It was clear from his evidence that the current administration of the DSE had worked to rectify perceived shortcomings.

The new asset management system enables the DSE to accurately identify the individual facilities of every school in NSW and to provide a detailed breakdown of both the size of each classroom and its use. It also allows comparisons between actual enrolments and maximum school capacity. This information is to be readily accessible at both a central and local level. Stage One will provide asset data on all secondary schools.

The Committee reviewed the implementation of the new asset management system at the public hearing for the current inquiry, beginning with an analysis of DSE methods for weighting different types of school facilities. The Committee then looked at the previous system for prioritising the bids by individual schools for facilities.

The DSE has operated a system for weighting different types of school facilities for some years. Obviously, issues relating to the health and safety of students receive the highest priority. For example, the installation of dust extraction fans in woodwork rooms or ventilation in duplicating rooms receives a higher priority than upgrading the school administration block. In addition, special priorities such as improved computer cabling periodically arise as a result of changes to government policy or amendments to the Building Code of Australia.

Weighting different types of school facilities has formed the basis for then prioritising bids to address shortfalls.

Mr Rowland indicated that the DSE had responded to funding constraints by concentrating on facilities shortfalls in areas and schools with the greatest needs:

The way the department has prioritised its programs for the past few years has been first on the basis of responding to absolute demand and whether the necessary requirements are met. This usually relates to new developments. The second priority is to endeavour to carry out major refurbishment on those schools which have the greatest number of deficiencies. The accumulated effect is taken into account: the number of demountable buildings, the age of the buildings, the extent to which services fall short of current standards, the time since specialist teaching facilities were last upgraded, the technology in the school, the size of the library and a whole series of issues. Having said all that,

it is possible to bring to the surface quite a large number of schools which have a priority, and this must be reduced to a much smaller number. It usually then becomes a question of trying to identify the most needy and, once on the priority list, ensure that the project does not just fall off and disappear, having been brought to the surface. (7-8)

Mr Rowland outlined the parameters of the new asset management system for the Committee and how it would work in tandem with new school facilities standards to produce an equitable distribution of resources across NSW:

We are within a few months of having a comprehensive registration system in relation to the extent to which all of our buildings do not comply with new standards and being able to quantify those in some empirically scaled way which will give the number most in need. I am looking at a way of codifying so that the most essential requirements will be the extent to which current facilities fall short of a school's entitlement under the new codes, based on its enrolment, and weight that according to growth. Therefore, growing schools will have a greater weight than static schools, which will have a greater weight than declining schools. Nevertheless, the most single characteristic would be the extent to which the buildings fall short of current standards.

The Committee questioned Mr Rowland on this whole-of-system approach to asset management:

Mr PRICE: How heavily would the regional structure impact on decisions for priorities?

Mr ROWLAND: In the past? The regional structure no longer exists.

Mr PRICE: The current structure.

Mr ROWLAND: The current district structure will not have an impact. We will not have district priorities. There will be a whole-of-system approach.

Mr PRICE: Is it a global view that is taken now?

Mr ROWLAND: Yes, and we hope that the first ground will be objective. Beyond that there are many forces which interact.

Mr PRICE: So your asset management plan is currently under way?

Mr ROWLAND: Yes. (8-9)

The Committee was concerned about whether community involvement would be maintained in a centralised asset management system. The previous system was based on the identification of shortfalls at a regional level through the participation of local committees.

Mr Rowland argued that the new system would provide a different type of community involvement:

Mr WINDSOR: With the change, do you see any impact flowing through of

lesser local involvement from parents, staff, teachers and cluster directors to identify some of those infrastructure problems?

Mr ROWLAND: I see a different involvement rather than a lesser involvement. What I am pushing towards is to publish the process and a list of the qualifying criteria. That has never been done before. It is quite a difficult task and it will not be without some controversy, I bet. Having done that, I would expect the department to receive submissions from schools, school councils, parents and citizens bodies, local members, local councils and interested citizens. I do not think there is a limit on who might make those submissions, but they would be strengthened if backed by a committee or local process. (9)

Mr Rowland went on to say that the DSE would be able to use its new asset management system to provide a quicker response to community submissions:

Essentially, I would aim to take those submissions and subject them to measurement using data from the asset management system and provide a fairly quick response: for example, "Look, I can see the need, but in terms of statewide priorities this is so far away from the front, come another time". I would say that in a nicer way, but the Committee would understand what I am saying. There is not unlimited capital and the process is always about identifying the greatest need. Out of that will come many submissions in relation to which there is a substantial case for something to be done. We would respond by agreeing that a substantial case has been put and that support and some resources will be provided to take the matter a stage further. There would then be a consultative process with the local community. We are very committed to that in the design of schools, but that is after an objective decision as to whether or not resources should be put into planning. (9)

Mr Rowland was candid in conceding that the existing system had not been able to accurately compare the relative levels of school facilities across the State:

Mr WINDSOR: In relation to transparency, are you saying that a whole lot of factors are involved in determining priorities on this holistic approach? How transparent is it? Is one school scaled against another to end up with a number out of 100?

Mr ROWLAND: Not at this moment.

Mr WINDSOR: Should there be?

Mr ROWLAND: I think so, and I am saying that is where we are going. It is some years since I first looked at this problem. It is very difficult without a detailed register of assets to be able to identify precisely the floor area, for example, for a set of existing buildings. The department did not have that data; it does now and that data is being assembled into the system. Some of the primary school data is being loaded over the next few months. The best data we

had was school cleaning data and even in 1990 most of that was in square feet, which to start with made it difficult to compare with the codes, which were in square metres, and it was not accurately surveyed. I do not wish to be critical—I have been part of this process for 10 years—but the technology to handle this sort of data was not available until very recently. It now is and we are proceeding to utilise it. (9)

It is apparent that the development of a comprehensive asset registration system by the DSE signifies the commencement of a systematic approach to long term planning for school facilities in NSW.

The construction of an empirical data base by the DSE to determine whether schools meet current entitlements - as laid down in the Primary and High School Facility Standards - will provide a standard gauge against which all schools in NSW can be measured.

The DSE will then be able to use this data base in association with projected enrolment figures to prioritise upgrading claims.

The Committee believes that the development of this comprehensive asset registration system by the current administration of the DSE represents an integral component in effective long range planning.

It will help determine whether individual school facilities meet entitlements under the Primary and Secondary School Facilities Standards.

1.9 The Facilities Maintenance Contract System

The DSE in conjunction with the DPWS has recently developed a new system of school maintenance, which will come online from 1997. It is called the Facilities Maintenance Contract system and replaces the earlier policy of Cyclic Maintenance, which had been in full operation since 1988.

As its title suggests, Cyclic Maintenance was designed to regularly refurbish school facilities according to a set timetable. It concentrated on the soundness of the building fabric, often to the neglect of facilities which were important to users such as floor coverings and grounds.

In evidence, Mr Rowland of the DSE outlined some of the problems that were arising because of the arbitrary time-frames imposed by Cyclic Maintenance:

Cyclic Maintenance was beginning to produce some degree of overservicing, particularly on the north coast. If it said that the schools had to be painted every five or six years, they were painted every five or six years regardless of whether the paint was worn out. (15)

According to Mr Rowland, Cyclic Maintenance was also a difficult scheme to administer because of the vast number of individual contracts which it involved:

Cyclic Maintenance involved hundreds and hundreds of contracts every year—some large, some small. There was some modification in recent years, particularly on the north coast, where we packaged a number of schools into one contract and reduced the number of contracts. Nevertheless, there was an enormous amount of work involved in specifying, estimating and documenting hundreds and hundreds of contracts each year. There was an emerging problem of how to supervise those contracts as the public service generally was looking for efficiencies. This was a particular problem for public works. (15)

Mr Zahn of the DPWS supported the evidence of Mr Rowland about the red tape associated with Cyclic Maintenance when he appeared before the Committee:

... there was a cyclic program that our client wanted. I suppose we advised them. That program was to paint every school in the State every five years. Supposing there are 2,000 schools, we were letting more than 400 contracts every year across the State. We did some sophistications in that but we still had to write 400 extended works, go to tender 400 times and undertake 400 supervisions. The Department of School Education was getting upset because we could not guarantee that the paint would last for three years or five years and even though we had brought the fees right down, it was still more than they wanted to pay—even though they knew what we were trying to do for them. (54)

Clearly, there were problems with Cyclic Maintenance in terms of over-servicing, prioritisation of works and administrative red tape which had to be addressed by the DSE in the interests of efficient and cost effective maintenance of schools.

A new Facilities Maintenance Contract system has been developed by the DSE and the DPWS to streamline schools maintenance by shifting responsibility to the maintenance provider.

In evidence, Mr Rowland explained that the new Schools Facilities Standards and Asset Management System would provide the DSE with a clear picture of the condition of NSW schools for the first time. This would serve as the foundation for determining maintenance requirements in schools across NSW:

We have defined the standards to which we wish schools to be maintained and we are completing an assessment of the condition of every school in New South Wales against a sophisticated, objective system that will report and quantify the work that needs to be done to bring the school up to standard. For the first time ever New South Wales will have a full report on its schools — for better or worse, we will know the condition of each school and what is required in terms of cost

to maintain each school over the next six to 10 years.

Mr Rowland outlined the principles which underpinned the new Facilities Maintenance Contract System:

The new maintenance contracts start from the philosophical position of whether it is possible to enter into an arrangement with the maintenance provider that will provide that provider with some reason to do good work and to look after it. The starting point was to give them a reasonably long time to look after the school, and the current thinking is six years, with the possibility of extending that to 10 years for good performance. That is the way that the initial contracts will be shaped.

The Facilities Maintenance Contract will bind maintenance providers to a six year, performance-based contract that is annually reviewed and renewed if performance is satisfactory. As Mr Zahn of the DPWS noted, "if they do not perform, they do not get the contract for the next year" (57).

The maintenance provider will be selected for each school district after a public tender. This contractor will have clearly specified responsibilities to keep schools in certain operating conditions in relation to serviceability, painting, plumbing and electricity infrastructure. Major pieces of replacement work such as a new roof or floor coverings will be separated and priced in the contract.

Mr Zahn explained to the Committee how the DSE and the DPWS used state-of-the-art computer technology to develop a method of assessing maintenance requirements:

... we bought hand-held computers that you put on your wrist and operate with a pen.... We download the floor plans for each school in a particular district into this small computer. The software is written such that the contractor goes out and it walks the contractor through the site and asks him to fill in what is wrong with the school. A contractor could walk into a room like this and call up E553, which would already have the size. And —here is the pearl — the contractor could say, "The ceiling has a leak". The ceiling is the element. The computer drops down the choices that the contractor has; he picks out the elements that are wrong; and when he tenders for it he puts a rate against ceiling repairs or floor repairs.... the computer rates that repair as priority one, two, three or four. Priority one elements must be done straight away. It is for other priorities that the contractor will periodically maintain the school.

Mr Zahn added that the new system provided an inbuilt incentive to maintenance providers to do a good job because they accepted responsibility to repair items that broke down at their own expense:

Also, in their tender the contractors tell us what they consider should be done to

the school over and above that. That is outside their risk. I suppose the other thing is that we are putting a lot of risk on the contractors to actually know what they are doing. If they do not fix a roof leak and the ceiling is damaged, it is their fault: they have to fix the ceiling. We are asking them to use their expertise to keep the schools running.

The relationship between the school principal and the maintenance provider will be the focus of the new Facilities Maintenance Contract system. It will empower principals to prioritise work that is essential to the ongoing operation of the school. They will deal directly with maintenance providers, significantly cutting time lags for repair and refurbishment. This will reduce the red tape involved in the old system in which principals had to contact regional bureaucrats for approval and organisation of repairs. Public Works will be conduct periodic audits of performance.

The first Facilities Maintenance Contract will be introduced in the Campbelltown district, which has 60 schools and a possible maintenance budget of \$20 million over the six years of the contract.

Mr Zahn of the DPWS summarised the operation of the Facilities Maintenance Contract system for the Committee:

The Facilities Maintenance Contract is a service contract, as Mr Rowland said, but it is a performance-based contract. That is probably the biggest difference. That means that we have, as part of the contract, a performance standard for each element within the school. We rate that element and we tell the contractor what the minimum standard is. For instance, obviously a roof cannot leak and the contractor has to meet that requirement. It is up to the contractors, over all the years they have the contract, to work out how they will keep the roof from leaking. Public Works used to say "Replace the second sheet in Block A northside". The contractors, with their expertise, are supposed to be able to go out and have a relationship with the principal and the school about what is going on. They have a performance standard to which they are supposed to keep the school. I suppose a very simple example would be that we used to paint every wall of a building but a contractor would probably paint the western wall three times in six years and wash down the other walls because they probably still look all right. Often it is the western wall that cops a hiding from the heat. The savings would be that the contractor will only maintain the things that need maintaining, rather than trying to do everything as we were. (54)

Mr Rowland argued that the Facilities Maintenance Contract system was designed to deliver better value for money rather than cut costs:

We are not attempting to cut the price; we are attempting to provide a better service to schools, attempting to be more directly responsive to schools so that they do not have to wait on approvals from large departments and so on. We have

certainly considered that sort of issue in some detail. (18)

The Committee accepts the rationale behind the new Facilities Maintenance Contract system.

Certainly, the combination of comprehensive School Facilities Standards, the new Asset Management System and state-of-the-art computer technology which will identify maintenance requirements promises to deliver better ongoing maintenance of schools in NSW.

The Committee supports measures to empower principals in the maintenance process, cut bureaucratic layers out of that process and shift responsibility to maintenance providers. It also seems to the Committee that the auditing and review system will be sufficient to ensure diligent service.

However, Members of the Committee raised concerns about the opportunities of local companies to successfully bid for work given the tendering process and the scale of the maintenance contracts.

In the course of his evidence, Mr Zahn stated that the new maintenance system was oriented towards large firms:

Part of public works for government is trying to change the culture of the building industry. We do not want fly-by-nighters, we do not want cheap builders, we do not want small firms; we want big firms that can manage themselves. We want them to manage the sites rather than the Department of Public Works and Services trying to tell them how to maintain the building. (56)

This evidence disturbed the Committee because of its ongoing commitment to enhancing opportunities for local companies in regional NSW. When questioned on this matter, Mr Rowland of the DSE argued that the new system would have a flow-on effect for local subcontractors:

We believe that builders who have to provide a 24-hour response service to schools in country areas will enter into arrangements with local builders to work on their behalf, as local representatives, but until it emerges we cannot be sure of that.

Speculation about flow-on effects is no substitute for action to encourage local companies to provide services as part of the new Facilities Maintenance Contract system.

There was also concern in the Committee about anecdotal evidence that regional companies had been screened out of the preferred tendering list:

Mr WINDSOR: One of the problems that has been brought to my attention is

that because of the preferred tendering criteria — the basis of which was having done work to the value of \$7 million — a lot of country businesses, building contractors, were fenced out of the preferred list, and that has caused some problems. I have raised this with the Minister, but the answer I am getting is that the big city firms that have the majority of the contracts across the State will use subcontractors. Does your department have some process by which it will ensure that when subcontractors are used the contractors will give them some degree of protection?

Mr RIXON: In other words, will it ensure that the big contractors pay the little contractors?

Mr WINDSOR: Some of the people who will get the major contracts have a history of problems with subcontractors.

Mr ROWLAND: I would have to request that you address that question to public works this afternoon. That is where the protection lies, in terms of the quality of the government contract.

Mr WINDSOR: If public works has failed in relation to other areas — it is something that you would want to be careful of because —

Mr ROWLAND: I am conscious of the problem. I will take it up, but I cannot answer the question here because I do not know the fine print of the contract well enough. (16-7)

Mr Rowland was specifically asked about the activities of the Schools 2000 Consortium in relation to tendering for maintenance contracts, which included the State Rail Authority (SRA):

Mr WINDSOR: Perhaps you could take this question on notice. There is some concern about the new corporatised Rail 2000 grouping getting some of those, being the preferred tender.

Mr ROWLAND: Rail?

Mr WINDSOR: I think it is called Rail 2000.

Mr ROWLAND: I do not believe that it is involved in the schools.

Mr WINDSOR: Well, it is. It is a preferred tenderer for the maintenance of schools.

CHAIRMAN: Perhaps you could take that question on notice.

Mr WINDSOR: The concern that has been raised is whether Rail 2000 will be able to offset some of its costs in relation to being able to compete with other private businesses.

Mr ROWLAND: That, in essence, is exactly the same reason that we have not made Public Works a tendering body for packages. It will do some districts, and it will do some districts without tendering in the broad sense, and it will be benchmarked against performance in the same way as the private sector. There is no preferred position.

Mr Zahn of the DPWS was able to provide the Committee with more information on the Schools 2000 Consortium later in the public hearing. He reassured the Committee that this consortium

would be receiving no special treatment when it came to considering tenders:

Mr ZAHN: One question concerned the SRA organisation approved tender for the new facilities maintenance contract. They are actually part of a consortium for other contractors and have a strategic alliance which is called Schools 2000. The firm, or tenderer, will be treated like any other tenderer with no special clauses in its relationship with us or the DSE in the way that we treat this tenderer against other tenderers. In fact, we have at least one other government body tendering for this work and that is the Australian Capital Territory public works department.

ACTING CHAIRMAN (Mr Rixon): The public perceives some groups as semi-government or part-government. Would those groups receive a special advantage in the tendering process through sales tax rebates or some other advantage that private enterprise does not have and that would make the playing field not completely level?

Mr ZAHN: As far as I understand it, the playing field for off-budget agencies is the same as for those tendering in the outside world: they have to make allowance for sales tax and fringe benefit tax. Unless I make a commercial internal decision, which any other firm could do, the process must be through the tender box and must be evaluated like any other tender. (47-8)

The new Facilities Maintenance Contract system will reduce the number of individual contracts initiated and administered by the DSE and the DPWS for the maintenance of NSW schools.

However, the Committee is concerned that this streamlining process may be to the detriment of local companies in regional NSW.

Past inquiries by the Committee have indicated that companies in regional NSW are being frozen out of the public works process by the capital-city orientation of government agencies and their preference for dealing with large firms.

Local companies are the lifeblood of regional communities, providing direct employment as well as boosting local small business.

Providing local companies with business opportunities has never been more important than in the current rural climate of recession, adverse climatic conditions and withdrawal of services.

The Committee renews its call for government agencies to develop formal strategies to enhance opportunities for companies in regional NSW to be involved in infrastructure provision.

There is also some anecdotal evidence that the preferred tendering criteria for the Facilities Maintenance Contract system may have disadvantaged regional companies.

RECOMMENDATIONS

1. **The Department of School Education and the Department of Public Works and Services develop formal strategies to enhance opportunities for companies in regional NSW to tender for public works on a level-playing field.**
2. **The Department of School Education and the Department of Public Works and Services review preferred tendering criteria for the Facilities Maintenance Contracts system to ensure that regional companies are not disadvantaged by the tendering process.**

1.10 Relations between State Government Agencies and Local Government

The Committee has examined the relationship between state government agencies and local government over the provision of public infrastructure in previous inquiries.

Representatives of government agencies have complained about the extent of supporting infrastructure which local government requires as part of Development Application (DA) approval process. This issue was raised again during this inquiry.

During his evidence, Mr Rowland indicated that the DSE was largely satisfied with the way in which planning was coordinated in NSW although it had been having trouble with development consent at a local government level:

CHAIRMAN: Are you happy with the level of cooperation from other government agencies?

Mr ROWLAND: On a broad scale in planning terms, yes. With any large organisation, from time to time there will be disagreements about criteria that apply to our development application, time frames and those sorts of questions. In fact, the question of development consent is a difficult issue for the department in some places at the moment. (3)

Mr Rowland was concerned about the manner in which local government effectively held the DSE to ransom over DA approval:

CHAIRMAN: Are things like car parking taken into account?

Mr ROWLAND: Car parking and the like, bus set-downs... Problems really emerge in the interpretation of the current rules for the particular exercise. As a generalisation, local government seems to have a tendency to wish us to take our involvement further off the school site and be responsible around about half a kilometre or a kilometre down the road. We are never quite sure where the

black line is that divides our respective responsibilities.

CHAIRMAN: I presume that represents an informal section 94 contribution?

Mr ROWLAND: It is a matter of negotiation. More often than not that kind of problem will hold up a development application. We will say that we do not believe our Minister has a responsibility for developing half of the roads in the shire, council or municipality, to exaggerate, and they will say we should because we will increase the amount of traffic. We will not comply and they will not approve. The matter will be referred to the Minister for Urban Affairs and Planning to be ultimately resolved. We will agree to abide by the referee's decision.

The evidence of Mr Rowland was reiterated by Mr Muddiman of the DSE when he appeared before the Committee:

Mr PRICE: What problems did you encounter with local government in relation to approval or provision of funding for supporting infrastructure at the school?

Mr MUDDIMAN: Ever since Crown developments became the subject of development applications local government has seen the department as a means of extracting contributions of the highest level possible for local infrastructure. No doubt it is a little payback for what went on in the past. There is no doubt that some restrictions and requirements of local government are unreasonable. Local government has certainly delayed quite considerably a number of school projects on the north coast and elsewhere. In saying that, I must mention that there is a notable exception. The Ballina Shire Council has operated in completely the opposite way and has done everything possible to facilitate new school construction and additional works in its area. That is certainly the only one in our area about which I can say that. (43-4)

Mr Muddiman noted that it was urban development often initiated - or at least approved - by local government which resulted in the need for extra schools. Thus, it was ironic that they should be demanding extensive additional works from the state government agency which was delivering this infrastructure.

Mr Muddiman suggested that an infrastructure levy should be added to DA approvals:

Mr PRICE: You described the circumstances in the Tweed area that necessitated the building of a school. How do you view the problem of large population growth? For instance, how is infrastructure provided in a new subdivision that requires through roads?

Mr MUDDIMAN: The problem is that local government approves the development and through increased population that development necessitates construction by government of infrastructure such as schools. The unfortunate part is that in giving initial approval local government does not seem to take

into consideration the needs of groups, such as the Department of School Education that must provide schools. Consequently, when we go to build we find that we are asked for quite substantial contributions to sewerage and water supplies. In view of the fact that our development comes directly as a result of action by local government, it is our feeling on the north coast at any rate that in approving the development local government should add a levy to any development to cover the cost of providing the infrastructure for government-provided infrastructure such as schools.

Mr Muddiman also noted the penchant of local government to ask the DSE to pay for car parks which were actually going to be used by community groups not students or staff:

Mrs BEAMER: Sewerage infrastructure was one of the biggest problems demanded by local government. Were there also issues like additional car parking?

Mr MUDDIMAN: Yes. The department's standard designs has an allowance for car parking. Inevitably local government requested additional car parking. In the case of high schools, the reason was that students now drive to school. Our response was that we allowed informal car parking on non-paved areas. Quite often we found that the reason local government asked for additional car parking, particularly with primary schools, related to the view that the school would be used widely out of hours by community groups. Consequently, additional parking would be required for that reason. Of course, we are in the business of providing educational facilities and not community facilities.

The Committee appreciates that the construction of new or upgraded public infrastructure - such as schools - increases the pressure on existing infrastructure and may necessitate upgradings to such items as sewerage systems and surrounding roads.

The current process for resolving disputes between local government and state government agencies involves adjudication by the Minister for Urban Affairs and Planning. This process is satisfactory.

The problem occurs when state government agencies cave in to unreasonable demands by local government rather than face delays in project approval.

One solution suggested by Mr Muddiman was a public infrastructure development levy.

The Committee will continue to monitor the issue of local government demands for state government agencies to fund supporting infrastructure.

1.11 Comments

School facilities planning and construction has become a complex task in recent years due to changes in population distribution, curricula, technology and environmental awareness.

These social changes have imposed additional pressures on the DSE and the DPWS to meet community expectations in existing and new school facilities within budgetary constraints.

The key to keeping pace is innovation.

There is ample evidence that the DSE - in collaboration with the DPWS - is seeking to find innovative ways of providing an optimal learning environment while gaining maximum benefit from valuable taxpayers dollars.

Recent measures include the development of detailed Schools Facilities Standards and a comprehensive Asset Management System. These features, in turn, have enabled the DSE and the DPWS to completely restructure the maintenance system for NSW schools by the introduction of the Facilities Maintenance Contract.

Together, these initiatives will enable the DSE to identify infrastructure shortfalls and promote educational equity across NSW.

In later chapters, the Committee will investigate other potential innovations which can be considered by the DSE and the DPWS for NSW schools including the introduction of more flexibility and range into the CDR, the use of high-quality relocatable lightweight buildings, sharing facilities between schools and enhancing energy efficiency strategies.

CHAPTER 2

LIGHTWEIGHT ACCOMMODATION IN NSW SCHOOLS

In this chapter, the Committee considers least cost construction strategies for NSW school facilities within the limits of its terms of reference, which require a specific focus on the relative costs and benefits of demountable school buildings as opposed to permanent lightweight buildings. This limits the Committee to primary schools, as lightweight buildings are not used in secondary schools because they are subject to a different building code.

However, it does not restrict the Committee's ability to consider wider planning issues in relation to school facilities.

For example, the use of demountable buildings to augment permanent infrastructure is part of the Core Plus strategy used by the DSE to meet surges in school enrolment levels around NSW.

The Committee has received detailed submissions from key stakeholders which chronicle user dissatisfaction with demountables.

The Committee believes that it is better to be realistic and acknowledge the funding constraints which make demountables necessary, rather than pretend that a quick fix solution is possible.

The focus of this Report is on innovations which will improve the learning environment in both demountable and lightweight accommodation.

The Committee conducted two site inspections as part of its inquiry. Relocatable lightweight buildings and shared facilities in the ACT were assessed. In addition, a range of DSE assets on the North Coast were examined including:

- A new Component Design Range (CDR) primary school at Centaur.
- A small rural primary school incorporating a range of North Coast Kit (NCK) buildings at Terranora.
- A kit library and classroom block incorporated into existing facilities at Murwillumbah East Primary School.
- A school composed almost entirely of demountable buildings at Pottsville Beach as well as the new CDR school which will replace it in 1997.

In this chapter, the Committee provides an outline of the different lightweight and demountable facilities being used in NSW primary schools and suggests ways in which their design could be refined and savings achieved. It also conducts a cost comparison of these facilities to review their cost effectiveness.

Finally, the Committee looks at a new concept in school facilities: a relocatable lightweight

building which is intended to combine the transportability of the demountable with the design enhancements of the permanent lightweight building.

The chapter begins with an overview of the strategy behind the delivery of school facilities in NSW.

2.1 The Core Plus System

Strategic asset planning for NSW schools follows the principles of providing appropriate resources in response to fluctuating needs. It is essential that assets are managed in a way that permits maximum utility within an overall framework of cost effectiveness.

To this end, the DSE now avoids the construction of permanent facilities which will inevitably become surplus to need at some point in the future due to changing demographics.

This policy is the outcome of experience with under-utilised facilities. Permanent schools built during the 1960s and 1970s in Western Sydney now have surplus accommodation capacity. These schools generate considerable ongoing maintenance and recurrent costs.

The Core Plus system was developed in order to avoid this type of overprovision. The history of school facilities leading up to the introduction of Core Plus was outlined in Section 1.2 of this Report. In addition, a graphic representation of the Core Plus system is contained at Appendix 3 of this Report.

Core Plus relies on the accurate projection of enrolment trends. Based on the results of detailed demographic assessment, permanent accommodation is planned for long term enrolment levels rather than any short term peak. Demountable buildings are used to supplement existing accommodation during peak enrolment years.

This strategy means that new schools will carry demountable buildings for a number of years and then shed them as enrolments fall leaving the school with a core asset base commensurate with its long term facility needs. This practice represents considerable savings to government and allows for the direction of resources to areas of greatest need.

In its submission to the Committee (s.7), the DSE also claimed that a further advantage of the use of demountable buildings in the Core Plus system was that an existing stock of buildings can be reutilised across a number of schools over a period of years with refurbishment as the only capital cost. This reduced waste, addressed inequity and correlated with the asset cycle. It meant that capital could be directed to the provision of permanent accommodation in areas where long term demand is experienced.

The Committee examines the lightweight school facilities used in the Core Plus system in Section 2.2 before looking at demountable buildings in Section 2.3 of this Report.

2.2 Types of Permanent Lightweight Buildings

There are two types of permanent lightweights which have been utilised by the DSE in NSW primary schools in recent years: the Component Design Range (CDR) of buildings and what are known as North Coast Kit buildings.

The CDR lightweight has been developed by the DSE as the design basis for all new primary school facilities.

Kit buildings, on the other hand, were developed at a regional level by the (then) North Coast Office of the DSE - in conjunction with the DPWS - in the late 1980s. They have been used to provide classroom blocks for small rural schools in the tropical climate of NSW's far north coast.

The Kit concept has been refined and developed by the DSE to provide permanent facilities for primary schools throughout NSW. The standard Kit home base design was completed in 1992. It has been successfully converted for use as a library and, more recently, as an administration block/library at Peats Ridge Primary School on the Central Coast.

The Committee was particularly interested in North Coast Kit buildings, which were the prototype for this program. There is a specific analysis of these facilities at Section 2.2.2.1 of this Chapter.

Both the CDR and Kit lightweight buildings are standard design, permanent buildings for primary schools only. In design and construction, they aim to provide cost-effective facility provision. As construction methods equate with project home construction techniques, they can be built quickly by a range of builders across the state.

In addition to these buildings, the DSE utilises demountable accommodation as part of its Core Plus strategy to meet short term surges in enrolments or as a temporary measure until permanent buildings can be constructed.

In the following sub-sections, the Committee outlines the features of these different lightweight school facilities.

2.2.1 *The Component Design Range (CDR)*

The Component Design Range (CDR) is a system of lightweight buildings used for primary schools.

CDR buildings are single storey constructions comprising brick veneer walls, concrete ground slab, metal roof cladding to pitched roof framing, internal stud partitions and aluminium windows.

A user-friendly guide to the features of the CDR is contained at Appendix 5 of this Report.

The CDR has been used for both the construction of new permanent schools and extensions to existing schools.

The Committee visited CDR schools at Centaur and Pottsville Beach during its site inspection of North Coast NSW. It also examined CDR additions at Terranora Public School. Ground plans for each of these schools are contained in the Maps at the end of this Report.

The CDR has become the standard design used by the DSE in primary schools because of its capacity to allow greater diversity in planning. It enables the DSE in conjunction with the DPWS and the school community to select the most appropriate and cost effective components for achieving desired school design.

The CDR comprises a selection of building plans, profiles, materials and elements which maximise choice. This flexibility has significant advantages for school planners and builders. They are able to:

- Plan and construct a school that is unique and that can be tailored to an individual site.
- Adapt to the specific needs of the school and community.
- Benefit from the use of pre-designed components based on the most successful examples of recent experience.
- Achieve best value for the available budget.
- Manifest environmentally friendly and energy efficient design principles.

All buildings include turbo ventilators and lighting strips to maximise the use of natural light and ventilation. The covered outdoor learning area (COLA) space is aggregated to provide one large protected space.

Options include the use of steel frames, trusses and load bearing walls. The design of windows, louvres and doors is consistent with the Primary School Facility Standards designs. Roofs are constructed with steel cladding and have a specified pitch and profile. Walls are constructed of brick to a height of approximately one metre with metal cladding above.

The design of CDR lightweight buildings has proven conducive to the integration of disabled students into regular classes. Because of the flexible nature of the CDR homebase, 'support units' for disabled students can be incorporated into the design as required. The Committee observed integration in action during its inspection of Centaur Primary School on the NSW North Coast.

The adaptability of the CDR to a variety of site terrains enables the buildings to be located as close to ground-level as possible. Such site options increase the general accessibility of the CDR buildings for disabled students and staff, and often enables access to be gained directly from ground level.

One area of concern to the Committee was the ability of the CDR to cope with the range of regional climatic conditions experienced around NSW. In a subsequent section, the Committee looks at the North Coast Kit buildings, which were developed at a regional level and provide excellent protection against the hot, humid environment.

The Committee questioned departmental witnesses about the capacity of the CDR to cope with different climates.

Mr Zahn of the DPWS argued that the CDR system had been designed to reduce costs while meeting school facilities standards and that the next stage in its refinement would be to build a degree of flexibility into design:

ACTING CHAIRMAN: You seem to be looking at New South Wales as a whole and not necessarily making the most of individual differences within the State. You may perhaps be using a more expensive glass in one area than you need. Is there any provision in what you are doing to ensure that various areas of the State have their particular problems considered?

Mr ZAHN: You are right in some ways. The component design range was developed so that we could reduce our fees in some areas but also have a quicker response time. I could have brought a folder. There are five classroom versions and there are three admins. The architect loses a bit of flair in some ways. It means that they can do a proper siting and be able to give a sketch plan the following week for a school that complies with the code. We are now looking at how we can customise it slightly, possibly match the looks, if it is an existing school, or the thermal conditions of the area we are putting it into. At the moment we have put forced ventilation at areas past the 33 isotherm—we have to do that, anyway. As far as customising any further is concerned, you are right; we are starting to look at that at the moment. That is an issue. The results we have using scientific analysis have been very good. (53-4)

The Committee agrees that the CDR delivers buildings which are functional, economical, easily constructed and environmentally responsive. They provide innovative solutions to the evolving needs of the system and the community.

In the next sub-section, the Committee examines the Post-Occupancy Evaluations of CDRs before going on to examine North Coast Kit buildings, which were designed by local DSE officers specifically to meet regional climatic conditions.

2.2.1.1 CDR: Post-Occupancy Evaluations

A key to monitoring the success of the CDR is the Post-Occupancy Evaluation (POE) process undertaken by the Schools Building Research and Development Group, a joint venture of the DSE and the DPWS.

Candid review by facilities users is the best means of confirming design utility and identifying areas where refinement is necessary.

The joint DSE/DPWS submission to the Committee (s.7) stated that each CDR facility was subsequently appraised by a POE. The DSE also provided the Committee with copies of school profiles and raw data for annual POEs.

The Committee examined the level of user satisfaction with CDR upgrades in the 1995 Post-Occupancy Evaluation Report.

The 1995 Post Occupancy Evaluation Report examined fifteen schools where CDR facilities were tested for user satisfaction by questionnaire.

There was uniform positive response for the CDR site layout and classroom design in the POEs for 1995. Respondents considered that school buildings had been successfully integrated into a unified overall design with covered walkways providing good access and protection. The sensitivity of DSE planners to retaining natural features was noted. Classrooms were considered to be very functional with an attractive appearance and good ventilation, light and storage. The provision of wet areas and withdrawal areas was also commended.

Areas highlighted in the POEs as unsatisfactory included the inadequate size of halls, the poor quality of fittings and workmanship, problems with drainage and leakage and lack of shade.

The Committee is not able to thoroughly examine POE results in the course of a single inquiry. Rather, the Committee examined the departmental response processes to satisfy itself that there was a serious review of POE results, leading to modifications to the CDR where necessary.

In evidence, Mr John Zahn of the DPWS gave an anecdotal example of one area where the POEs had led to a change in the CDR:

Mr ZAHN: Our report looks at post-occupancy evaluations. Both departments are investigating a school's acceptance within the community and we are all the time making incremental changes to our designs. Therefore, we are not standing still. One of the changes is that previously we had a tiered learning space, which is a space beside the library that is like a mini-theatrette.

Mrs BEAMER: I have seen that.

Mr ZAHN: Post-occupancy evaluations showed that no-one really used them. We have now taken out the stairs and airconditioning and left it as a carpeted room with a bench in the corner. That has left a flow of space that can be used by the school for reading recovery and other useful purposes. We have saved money and given schools a better answer. Those are only a couple of innovations that are under way at the moment. (51-2)

The Committee followed up this matter in its Questions on Notice to Mr Zahn.

The Committee was primarily concerned with any modifications to the CDR since its inception. Mr Zahn replied:

Although there has been fine tuning of some materials and features, along with improving the Contract Documentation and Performance specification in response to on-site feedback, the design has remained basically the same due to its success

as evidenced in the annual Post Occupational Evaluations (POE). However, two categories of changes are now being finalised. These are:-

- **Plan Changes:** In response to the POEs. Relatively minor in nature due to the overall success and ongoing currency of the original planning.
- **Construction Design Option:** In response to ESD design and 'buildability' issues, DSE & DPWS have developed a 'Timber' CDR option using the above plans. This consists of:-
 - All the structure, ie. wall frames & posts, roof trusses, etc. are in treated timber from plantation or sustainable managed forests. This is for all buildings except halls, which have steel frames due to the large spans involved.
 - Roof pitches are reduced to line up with walk way roofs. This reduces:
 - Building volume.
 - Winter heating.
 - Height of walls.
 - Quantities and Cost of structural elements and materials.
 - Environmental Burden due to less materials.
 - Eaves:- These have been simplified and made more economical by:
 - Omitting perforated corrugated steel eaves lining.
 - Omitting half round gutter & brackets and replacing with standard quad guttering.
 - Omitting cold rolled steel eaves angle.
 - Gable Roof Overhangs:- These have been extended to increase sun shading to the gable end walls, and so reduce thermal gain within buildings.
 - Roof Insulation:- The 75 mm, R2.5 insulation blanket has been repositioned on top of the ceiling, and another layer, 50 mm, R1.5 has replaced it under the metal roof to:-
 - Avoid deformation of the metal roof through being fixed down on thick insulation.
 - Place the primary insulation blanket next to the ceiling to protect the rooms below from the greater heat and cold of the roof space in summer and winter respectively.
 - External Finishes:- These remain unchanged in that the standard format is:-
 - Brickwork up to door head height, and lightweight cladding (usually colorbond steel) above.

The Committee is satisfied that the Post-Occupancy Evaluation (POE) process is acting as a methodical review of the Component Design Range of lightweight school buildings.

The POE is the primary avenue for school facilities users - be they teachers, students, parents or the community - to offer feedback to the DSE and the DPWS about school facilities design.

An area of concern to the Committee was the poor response rate of teachers at some schools to the POE survey. Overall, 215 out of 309 teachers completed the POE survey in the fifteen CDR schools studied by the Committee. This represents about a 70% response rate. However, there were some schools where less than half of the teaching staff completed POE surveys.

Principals, teachers and support staff are the most articulate and experienced group of school facilities users.

The Committee believes that the DSE should implement strategies to encourage staff to complete POE surveys.

Another area of concern to the Committee in examining the results of the 1995 POEs was the lack of input from students, parents and the community. Out of 218 respondents over the fifteen schools in the POE report, only 11 parents and one community member completed surveys.

The Committee believes that a more broadly-based survey may be beneficial.

RECOMMENDATIONS

- 3. The Department of School Education implement strategies to encourage the completion of Post-Occupancy Evaluation surveys by all staff.**
- 4. The Department of School Education promote a more broadly-based survey pool for Post-Occupancy Evaluation surveys including input from students, parents and the community.**

2.2.2 Kit Buildings

Kit buildings have come into prominence in recent years as permanent lightweight school facilities which offer a viable alternative to demountables for schools with sustained enrolment increases.

The Kit building concept originated on the NSW North Coast in the late 1980s when the DSE was looking for a high quality, lightweight school facility which could be funded through the Minor Capital Works program.

The Kit range has since been extensively refined and upgraded by the DSE to meet a variety of school facility needs including libraries and library/administration blocks.

Kit facilities are single storey constructions comprising:

- Metal-clad exterior walls (although end walls often have brick facing)
- Metal roof cladding to pitched roof framing
- Turbo vents fitted to the roof to enhance ventilation
- Suspended timber floor supported on brick piers
- Internal stud partitions
- Aluminium windows
- Designated wet area
- Withdrawal room
- Ramp to enable disabled access
- Optional skylights.

Plans of standard kit buildings are contained in Maps 6-8 at the back of this Report.

Kit buildings are the most economical NSW school facility to construct and provide comparable life-cycle costs with the CDR over a 50 year cycle. The Committee examines the comparative costs and benefits of the range of lightweight facilities in the NSW school system in Sections 2.5 and 2.6.

Kit buildings are also highly-compatible with existing facilities. The Committee looks at this issue in detail in Section 2.7 of this Report.

The Committee believes that kit buildings offer a high quality, cost effective and flexible permanent school facility with significant potential for further use in the NSW education system.

Kit buildings are ideal as an “add on” to existing schools because they harmonise with both traditional and CDR facilities. They have been particularly successful in growth areas and smaller regional schools, where a high level of user satisfaction is recorded.

The key to using Kit buildings as an alternative to long term reliance on demountables is good long term planning and demographic analysis to identify schools which can expect sustained enrolment increases in the future.

The DSE has introduced a new Asset Management System and improved demographic forecasting which should enable it to accurately target schools where student numbers will grow.

This will enable the DSE to further reduce the use of demountables as de facto permanent accommodation.

In the next sub-section, the Committee assesses the North Coast Kit range of facilities, which provided the prototype for this program.

2.2.2.1 North Coast Kit (NCK) Buildings

The Committee inspected a variety of kit buildings during its site inspections for this inquiry including those on the NSW North Coast which originated the kit building program.

North Coast Kit (NCK) buildings fall within the lightweight category of school facilities. They comprise a range of pre-designed components which can be quickly adapted to service the particular needs of a school.

The NCK buildings were developed by the North Coast Region of the DSE in the late 1980s and have been used since 1990-91 to replace demountable accommodation where long term high enrolment levels are being experienced. The focus of NCK buildings as replacements for demountable accommodation means that they are geared towards rapid construction and strict cost control.

In evidence before the Committee, Mr Dave Muddiman (Manager, Lismore District Office, DSE), outlined the conditions present on the North Coast which led to the development of the NCK buildings:

ACTING CHAIRMAN (MR RIXON): You were closely involved with the development of the north coast unit. Will you explain the circumstances which necessitated the development of that type of unit?

MR MUDDIMAN: Certainly. As you are aware, the Department of School Education was, until recently, administered on a regional basis. In the north coast region we had a large number of small schools - the largest of any region in the State - and were growing at a much faster rate than any other country region. This led to a number of problems. Many of the small schools were single timber classroom buildings that were built sometimes as far back as the turn of the century, and did not lend themselves very well to modern teaching requirements. As growth occurred at these schools accommodation was provided through demountable classrooms. These demountables are a scarce resource and do not offer the most ideal teaching conditions in the north coast area in particular, where the climate is fairly harsh.

As a result, we developed a low-cost classroom block that in our view could be used to replace the demountable accommodation which, although designed for emergency purposes, was in fact de facto permanent accommodation.

Mr Muddiman added that the North Coast Unit was intended to be funded through the Minor Capital Works Program (under \$500 000).

The NCK buildings are single storey and constructed from one of three external claddings (brick veneer, colorbond, Hardiplank) with treated timber frames, a suspended timber floor on brick piers, metal roof cladding to a pitched roof frame, internal stud partitions, and aluminium windows.

The roof of the NCK building is the most notable design feature, consisting of a ten-foot high ceiling and ceiling vents to facilitate improved air flow through the building. Also of note are verandahs on either side of the building which protect occupants from the heat of sun and enable these buildings to be sited on a north-south aspect.

The classrooms meet the criteria set down by the schools facilities standards. They have the appropriate floor area in the classroom, a practical activities area, storage and a COLA.

The cost of NCK buildings depends on the type of exterior cladding used. The cost of a two classroom unit is:

- Hardiplank - \$149,190
- Colorbond - \$150,000
- Brick veneer - \$175,785

The construction of a NCK block is slightly cheaper than comparable CDR buildings (at about \$165 000) because NCK buildings use domestic construction materials and can be constructed by cottage builders.

When questioned on the maintenance requirements of the NCK buildings, Mr Muddiman responded that the materials used in construction had proven to be extremely sturdy:

MR MUDDIMAN: The buildings were designed to be as low maintenance as possible. The use of Hardiplank cladding lent itself very well to plastic paint finishes, and our experience was that we could easily get seven years out of them before they required repainting. The roof was colorbond and therefore needed little attention. We tried colorbond cladding, which is completely maintenance free or long-term maintenance free - that was using a profile which closely resembled weatherboards - and that also has performed very well. Of course, the brick veneer building is basically maintenance free.

The Committee visited Terranora Primary School, which is primarily constructed of NCK buildings, during its North Coast site inspection in October 1996. The layout of this school is contained at Map 3 of this Report.

Terranora Primary School was redeveloped over several years using the NCK buildings. In the final construction stage, a school hall has been built using the CDR design. The hall has been jointly funded by the local community and DSE so that it can be used as a shared facility.

Mr Muddiman elaborated on the case of Terranora primary school in his evidence before the Committee:

MR MUDDIMAN:Terranora is a...small school with a one-teacher timber building which, with the development of the Tweed, suddenly found itself in a

population growth area. The Capital Funds are divided into two areas. One is the capital for new school buildings and the other is for Minor Capital Works. At that time we knew that it would be unlikely that a brand-new school would be in the foreseeable future be constructed at Terranora. We came up with the idea of constructing a new school through the periodic construction of the North Coast Units and the Minor Capital Works Program. One or two units were built each year and we also incorporated our administration block design, which was part of the design range in the North Coast Units. Eventually a completely new school was built over a period of years using the North Coast Units, and I believe the community is very happy with it.

The Committee also inspected Murwillumbah East Primary School, where a NCK classroom block and library have been integrated into core facilities that are about 30 years old. The classroom was completed in February 1995 at a cost of \$332 825. The library, which cost \$211 385, was based on the classroom block design and completed shortly before the Committee's visit in June 1996.

The Committee questioned Mr Muddiman about the history of the library complex at Murwillumbah East Primary School:

ACTING CHAIRMAN: Would you outline the process and the changes involved in the construction of the Murwillumbah library?

Mr MUDDIMAN: Murwillumbah East was in grave need of a library but unfortunately never got one because of the problems of flooding on the site. As I mentioned earlier, the standard department buildings generally use a concrete slab construction. So to build one at ground level there was going to be an expensive business and not very practical. We used our North Coast Unit design, which is basically a double classroom block, but configured inside as a library. Originally I do not think it was intended to fund a school library, it was intended to fund a further two classrooms, but we prevailed upon the central administration to convert that funding into a library which was slightly less than two classrooms, to which it agreed. Unfortunately, the library was built towards the end of the regional operation and I believe the principal prevailed upon the builder to install vents in the ceiling. As a result the building is quite cold in the winter. As far as I am aware, they are the only variations that took place.

The NCK classroom block was modified for the library at Murwillumbah East Primary School, resulting in some design problems.

The Committee was told that the design would be improved if:

- the ceiling vents could be closed in winter.
- window size was raised to allow shelf height to be raised and make room for noticeboards.

- the audio visual room was larger.
- shelves/racks allowed for bigger books.

The Committee was particularly concerned about the audio-visual room, which was effectively useless for its intended purpose and being used as a storage room.

On the other hand, the construction of the NCK buildings on brick piers - rather than on a concrete slab as with the CDR buildings - was essential to the provision of any facility at all at Murwillumbah East Primary School due to problems with flooding on the site.

The Committee accepts that the Component Design Range (CDR) offers an integrated, high standard and cost effective system for providing school facilities throughout NSW.

The DSE has been endeavouring in recent years to combine comprehensive asset management and detailed school facilities standards to compose a total picture of facilities entitlements.

A total school facilities design system - such as the CDR - is essential if infrastructure shortfalls are to be properly addressed.

However, the Committee believes that regional expertise must be retained to ensure the provision of school facilities which can cope with the wide range of regional climatic conditions in NSW as well as specific localised problems.

The Committee commends the initiative shown by the DSE officers who developed the North Coast Kit (NCK) buildings to overcome funding problems.

The capacity to fund NCK buildings through the Minor Capital Works Program enabled the effective construction of a new school at Terranora on a stage-by-stage basis.

There are also design features in the NCK buildings which are superior to the generic CDR for the north coast climate.

These design options should be considered for incorporation into the CDR.

Equally, however, the NCK library at Murwillumbah East Primary School showed evidence of the difficulties of converting the NCK design to other purposes. In such instances, the superiority of a facility-specific design - such as the CDR - or the standard Kit building is obvious.

The Committee believes that the DSE has already reached a high level of refinement with its CDR and Kit buildings. Clearly, it has identified enhanced flexibility - particularly to meet adverse climatic conditions - as the next stage in refining school facilities.

The DSE and the DPWS are already engaged in consultation with facilities users to identify such design enhancements.

The Committee endorses this policy.

RECOMMENDATIONS

- 5. The Department of School Education continue to refine school facilities to enhance their flexibility to meet the specific climatic and site requirements of different regions of NSW.**

It is important that the Department of School Education should continue its approach of liaison with relevant officers and professional people from within the region affected.

2.2.3 Design Innovations in ACT Schools

The site inspection of school facilities in the Australian Capital Territory (ACT) enabled the Committee to examine a range of design alternatives to the CDR and Kit buildings developed by the DSE.

A lightweight school built by the Catholic Education Office (CEO) for St Clare of Assisi Primary School at Conder in the ACT was inspected. It contained design innovations in the hall and administration block which may improve existing CDR designs.

The Committee questioned the Project Officer for the CEO, Mr Tony O'Donnell, at its public hearing about the hall design at Conder:

CHAIRMAN: I refer to the design features at Conder. When I looked at it, some aspects seemed worthwhile, such as utilising the canteen for both schoolchildren and for the hall.

Mr O'DONNELL: The plan for the hall at Conder is for a general hall. The canteen has one side going out for the children to use and the other side comes into the hall for after-school functions or after-school care. All the commercial stuff is around the hall such as the uniform shop, the bookshop and all that. The hall has come up extremely well and we are happy with it. You could put the whole school in the hall, but you would not have a chair for each child. We bought 400 chairs, but the little ones could sit on the parquetry floor—it is not too bad. (37)

The design at Conder also contained an observation area where young children could be placed and monitored by parents while they served in the canteen. It included a change room and toilets.

The Committee also inspected the administration block at Conder, which contains design features which may address problems with this facility in the CDR.

Submissions to the Committee indicated a level of dissatisfaction by teachers with the lightweight administration blocks in the CDR. This attitude was supported by the result of a survey of principals undertaken by the NSW Primary Principals' Association - and included in its submission to the Committee (s.6) - as well as the results of the 1995 Post-Occupancy Evaluations of school facilities undertaken by the DSE.

The Committee asked Mr O'Donnell of the CEO to explain the features of the administration block during evidence:

CHAIRMAN: The administration block is unique at Conder. Could you give us some idea of the features that have been incorporated into it?

Mr O'DONNELL: There is the principal's office, a boardroom, a general office, a general staffroom, and all the other facilities. There are also showers, toilets and an outside courtyard. That has been done within budget and it is a good feature for the staff. I was surprised — I thought it would be looked down on by some of the parents, but they have encouraged it and said that that is what they need.

The Committee was particularly impressed with the large, private open area for teachers:

CHAIRMAN: I presume that the homely atmosphere in the staff administration area has been met with acceptance by the teachers?

Mr O'DONNELL: Yes, it has been accepted by the teachers. It has been worth while spending the money.

CHAIRMAN: It incorporates an open area.

Mr O'DONNELL: Yes, there is a big courtyard area where they can go.

CHAIRMAN: And that is separate from the playground?

Mr O'DONNELL: It is bricked off from the playground—the children cannot get in there. It gives the teachers some outside relaxation without them having to go into the playground. (37)

The Committee was impressed by the design of the hall and administration block at Conder, ACT.

The hall contained a flexible canteen area that included a child monitoring area. The administration block provided teachers with a spacious withdrawal area.

The Committee acknowledges that the lightweight facilities at Conder, ACT, were more expensive than the CDR. Construction costs were \$1 006 per square metre compared with \$606 per square metre for CDR buildings. The Committee is certain that the least cost construction strategies which have been implemented by the DSE and the DPWS would

substantially reduce this cost difference. However, some extra cost is justified in this case.

The Committee believes that the School Building Design and Research Group (SBD RG) is the appropriate mechanism for reviewing the facilities at the CEO school in Conder, ACT with a view to their incorporation into the CDR.

RECOMMENDATIONS

- 6. The Department of School Education commission the School Building Design and Research Group to study lightweight facilities constructed by the Catholic Education Office (Archdiocese of Canberra and Goulburn) at St Clare of Assisi Primary School, Conder, ACT with a view to incorporating innovations in the hall and administration block designs into the Component Design Range.**

2.3 Demountable Buildings

The Committee investigated the types and numbers of demountable buildings in use in the NSW education system as well as the cost of their refurbishment and relocation.

Demountable buildings are robust box-section constructions that have been specifically designed to withstand multiple relocations over a number of years.

They were originally intended to provide accommodation in emergency situations and temporary facilities during periods when schools were experiencing peak enrolments.

Demountable buildings are constructed of a modular steel frame comprising aluminium clad infill panels which is supported in brick piers. They have metal roof cladding to flat roof framing and aluminium windows.

Demountable buildings are pre-fabricated in factories using a standard set of drawings to construct the building envelope. Each unit consists of a number of modules which can be separated to allow vehicular transportation. The modules are then be reassembled in various sizes according to school need.

The Committee was particularly concerned with the propensity for temporary demountable accommodation to become de facto permanent facilities.

In part, this tendency is due to the durability of demountables.

In evidence before the Committee, Mr John Kimball of James Hardie Building Systems praised their sturdy construction:

One problem with the old demountables was that they were a temporary solution, but they tend to last magnificently. Thirty years later they are still there because the engineering was magnificent.

While demountables may be defensible from a strictly engineering point of view, the Committee was more concerned with their impact on users in the NSW education system.

In the next sections, the Committee examines the rationale for using demountable accommodation in the NSW school facilities system and compares these reasons with their actual role. The weaknesses of demountables are also identified and possible solutions offered including refinements to the refurbishment program in the short term to improve student comfort and the possible replacement of demountables with purpose-built lightweight relocatable buildings in the longer term as existing units reach the end of their life-cycle.

2.3.1 Types, Numbers and Value of Demountables

There are two types of demountable buildings used by the DSE. They are known simply as Old System and New System demountables and are distinguished by age and size.

The first demountable buildings were constructed in 1965 and the last in 1988.

No demountable buildings have been constructed since 1988 although they continue to be maintained and refurbished. They are still incorporated into school building plans.

Old System demountables began construction in 1965. Each module of the Old System demountables measures 7.6 m x 2.4 m, giving a total floor space of 18.24 sq m.

New System demountable buildings commenced construction in 1984. These demountable buildings represented a positive design development through the provision of a larger learning area. Each module of the New System demountables measures 9.2 m x 2.4 m, giving a total floor space of 22.08 sq m.

The last demountable construction program was for fifty of the four module (New System) units.

The construction cost of each unit was \$80,080 (excluding fees for architectural and construction supervision services). The equivalent cost of these buildings in July 1996 would be \$88,600.

The DSE/DPWS submission to the Committee (s.7) stated that the DSE possessed 5 560 demountable buildings of which 5 238 were in use in the NSW education system in 1995.

Demountables are used in over 1 000 schools across the state with 43% located in the Sydney metropolitan area and 57% located on country schools. A small number of demountables are held in reserve for emergencies.

Table 7 on the next page provides a breakdown of demountable use by region for 1995.

TABLE 7: Students and Demountables by Region - 1995

Region	Number of Students	% of Total Students	Number of Demountables	% of Total Demountables
Hunter	82 239	11%	697	13%
Metropolitan East	100 163	13%	430	8%
Metropolitan North	106 470	14%	517	10%
Metropolitan South West	102 800	14%	727	14%
Metropolitan West	116 007	15%	670	13%
North Coast	61 973	8%	687	13%
North West	31 297	4%	296	6%
Riverina	37 505	5%	221	4%
South Coast	72 575	10%	560	11%
Western	44 879	6%	433	8%
Total	755 907		5 238	

Department of School Education, *Reply to Questions on Notice*, 09/04/97, p3.

The data in Table 7 indicates that the Metropolitan East Region and Metropolitan North region have low proportions of demountables (8% and 10% respectively) compared to their share of students (13% and 14%). Alternatively, the North Coast Region has a large proportion of demountables (13%) compared to its share of students (8%).

Analysis of this data enables the DSE to assess priorities for resource allocation, which may include the replacement of demountables with lightweight kit buildings.

Funding for demountable relocation and refurbishment is outlined in the DSE's Annual Report under the Annual Provisions component of the Capital Works Program. Table 8 provides a breakdown on funding for demountable relocation and refurbishment in recent years.

TABLE 8: Annual Demountable Funding 1994 - 1997

YEAR	RELOCATION COSTS (\$ million)	UPGRADE COSTS (\$ million)	TOTAL (\$ million)
1994/95	10.4	4.2	14.6
1995/96	9.5	3.0	12.5
1996/97	7.0	4.0	11.8

This funding allocation includes the maintenance and transportation of demountable buildings. The Committee addresses both of these subjects later in this section of the Report.

It is estimated that the replacement construction cost (1996) for a single four module Old System demountable would be about \$84 000 including fees and installation costs.

Replacement construction cost (1996) for a single four module New System demountable would be approximately \$116 500 including fees and installation costs.

In its submission to the Committee (s.7) the DSE noted that “the replacement cost of the 24 000 existing modules of all demountable types is estimated to be in the order of \$480 million.”

Despite the immense cost of replacing demountable buildings, the existing stock of demountables has minimal resale value. In order to gain some indication of their resale value, it should be noted the DSE purchased demountables in good condition from the Commonwealth Department of Immigration at \$1 000 per module.

It is, therefore, not economically viable for the DSE to rationalise its demountable stock because of the discrepancy between the cost of replacing demountables and their resale value. Given the DSE’s current budgetary constraints, demountable buildings will continue to be used for purposes outside the original intention.

In this context, the Committee was concerned about whether any more demountables would be constructed and raised the matter during its public hearing. Mr Rowland of the DSE stated that the current demountable stock was sufficient for the next 20 or 30 years:

Mrs BEAMER: You have not constructed any new demountables since 1988. Do you envisage the construction of new demountables?

Mr ROWLAND: Not of the kind that we currently use. Our hope and our aim is, at least for the next 20 or 30 years, to refurbish existing stock. The refurbishment of an old, quite badly rusted demountable through an off-site refurbishment in a factory is about half the cost of a new one and it comes back to new service life. There are obviously advantages in doing that rather than having new ones built. Also, it does not change the design; we keep the same basic operation that people are used to but we modernise it and update the wiring and heating. Many demountables are being fitted with airconditioning. We are working on that.

The Committee believes that there should be no further construction of demountable buildings of the type currently in use in the NSW school system.

Community and user dissatisfaction with demountables was a feature of submissions received by the Committee, although all stakeholders acknowledged the need for demountables to remain in use in the system.

Given the fact that existing demountables will remain in use, the Committee sought

evidence of any developments in building design and technology which would enable future demountable buildings to meet expectations for the standard of school facilities.

In this regard, the Committee investigates the relocatable lightweight building concept in a later section of this chapter.

2.3.2 *Demountable Uses*

The use of demountable buildings as temporary accommodation has proven to be beneficial for the DSE on a number of levels.

In its submission to the Committee (s.7), the DSE listed the following instances where demountables were used:

- To meet *emergency needs* as a result of fires or natural disasters. Demountables enable the DSE to restore schools to some semblance of normal operations quickly. An entire replacement school can be erected in two or three weeks. Recent examples include the replacement of Como West Primary School after bushfires, Belmont and Hampden Park Primary Schools after arson attacks, schools at Nyngan after floods and schools in Newcastle after earthquake.
- To service *changes in enrolments* due to demographic change. These issues have been discussed in Chapter 1. Demountable buildings become necessary within the current system for short to medium term relief of increased enrolments.
- To service *changes in government policy* (e.g. staffing changes, class size variations and revised curriculums).
- To provide *temporary accommodation during construction of capital works in schools*. In some refurbishment projects, particularly staged major high schools, can take up to three years to complete. Demountables enable schools to continue to function with minimal disruption.
- To provide *accommodation on alternative sites* to enable the delivery of educational programs (e.g. hospitals and field study centres).
- To assist other *government departments* in cases of emergency or to fulfil their short term accommodation needs. A rental fee applies.
- To assist *non government schools* in emergency situations or during capital works programmes. A rental fees applies.

In addition, the versatility of demountables enables them to be used for a variety of functions within the NSW education system.

Currently, there are 121 different demountable configurations in use in NSW schools providing general learning spaces (classrooms), specialist learning spaces, libraries, administration blocks, food service and shelter units, change rooms, showers, toilets and storage. These units are used to complement existing permanent accommodation in over 1 000 schools across the state.

The DSE submission (s.7) acknowledged that demountable buildings have become de facto

permanent facilities, noting that “a significant proportion of demountable buildings are used for long term accommodation needs.”

2.3.3 Allocation of Demountables

The procedure for relocation of demountables is based on specific criteria including the level or type of school, a rigorous application process based on school entitlements and established priorities for allocation.

Criteria

Criteria for the allocation of demountables include the level or type of school, the standard of existing accommodation and the need for specialist demountables.

For *primary/infants schools*, demountables are usually allocated when the number of official classes exceeds the number of classrooms, based on actual and projected enrolments. Specialist facilities are provided to schools on a needs basis.

For *secondary schools*, the process for gaining demountable accommodation is more complex. Demountable classrooms are provided when the school’s actual and projected enrolment entitles it to a staff level which exceeds a maximum occupancy ration formula. This formula is total staffing (less the non-teaching component made up of executive allowance, concessional allowance, itinerant staff, counsellors and librarian) multiplied by 0.776. In cases where schools are releasing demountable classrooms the formula is relaxed by multiplying the adjusted staffing by 0.8.

For *central schools*, a combination of both primary and secondary criteria is used to determine demountable accommodation needs. The quality of existing accommodation is taken into consideration when considering the need for demountables. The minimum acceptable size for a secondary classroom for 30 students is > 38 sq.m and > 47 sq.m for a primary classroom or 2 sq.m per student, whichever is less. Specialist demountable accommodation is provided on the basis of an entitlement related to the Secondary School Facility Standard.

Application Procedures

Applications for demountable accommodation may be made by a school at any time during the year as the need arises.

Applications are submitted to the Demountable Coordinator through the Manager, School Service Unit.

All applications generated by a school are assessed by the School Service Unit which confirms that an educational need exists and that the supply falls in line with the Department’s accommodation code.

The Manager, School Service Unit confirms that the requested accommodation is within the approved guidelines.

Where an entitlement exists the application is forwarded to the Leader, Demountable Co-ordination for approval and/or processing. If there is no entitlement, the school is told that the application has been rejected.

In the case of movements of general teaching spaces for the commencement of the school year, no application need be submitted by schools. These movements will be arranged following liaison between the Leader, Demountable Coordinator and School Service Units.

The supply and allocation of demountable accommodation is arranged on a Statewide basis by the Demountable Coordinator. Following approval, the Demountable Coordinator advises the School Service Unit, District Properties Officer and Principal that the accommodation has been approved and will be supplied when the building becomes available.

Where an application is deferred, the School Service Unit will be advised of the decision and requested to re-submit a fresh application when firm enrolment figures are known.

Priorities

Priority in allocation of demountable accommodation is determined according to the following criteria:

- Priority 1 - Emergencies such as fires and natural disasters.
- Priority 2 - Needs arising from increased enrolments.
- Priority 3 - Needs arising from Capital Works Projects and Major Maintenance projects.
- Priority 4 - Accommodation enhancements such as replacement of undersized rooms.

The Committee believes that the present system of demountable allocation has been effective. Where demountable buildings are warranted, the DSE has operated within an appropriate time-frame.

2.3.4 Demountable Movements

The transportability of demountable buildings has been promoted as one of its advantages in the Core Plus system. It enables demountable accommodation to be quickly installed on site to meet enrolment surges or emergencies.

The Committee was interested in the number of demountable buildings which were relocated during a typical summer break and the method of transportation including costs.

In the public hearing, Mr Rowland of the DSE was asked about demountable movements during the summer break of 1996-97:

Mrs BEAMER: Are you able to tell the Committee approximately how many demountables have been relocated during the 1996-97 summer break? You may take the question on notice if you wish.

Mr ROWLAND: I would have to take the question on notice in order to be precise. It will be of the order of 700 in this particular break.

Mrs BEAMER: Is that a consistent pattern?

Mr ROWLAND: It has been a little lower this year than in the past few years. In the past few years we have consistently moved them. There has been a gradual decline over the past 10 years from about 1200 movements 10 years ago to about 900. This year it seems to be a little lower again, for some reason.

To confirm Mr Rowland's anecdotal evidence, the Committee provided the DSE with a Question on Notice requesting recent data on the relocation of demountable buildings, both during the 1996-97 summer break and as a general trend over the past five years. The reply from the DSE indicated that on the whole there has been a general decline in the movement of demountables over the past five years. This information is contained in Table 9 below.

TABLE 9: Trends in Demountable Movements, 1987-88 to 1996-97

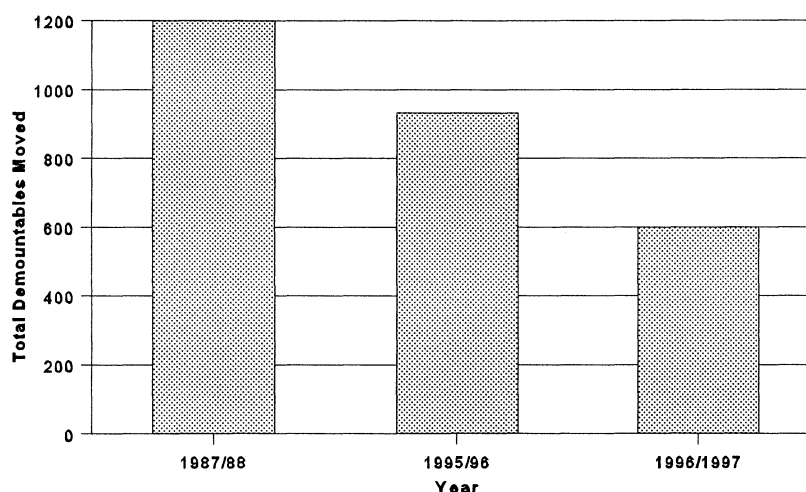

DSE data indicates that there were 600 demountable movements in 1996/1997 of which 266 occurred over the Christmas vacation period. There were 933 demountable movements for 1995-96, of which 318 occurred over the Christmas vacation period.

The decline in the number of demountable movements over these years is quite significant compared to 1987-88 when approximately 1 200 demountables were relocated over the year.

The cost of relocating demountable buildings varies depending upon the difficulty of removal from the existing location, distance for transportation and condition of the new location.

In evidence, Mr Rowland noted that the cost of relocating demountables depended predominantly on the type of module being relocated:

Mrs BEAMER: What is the cost of relocating the demountable buildings, including transport?

Mr ROWLAND: For an ordinary classroom, typically from about \$7 500 to \$8 000. For a specialist building - particularly a laboratory, cooking room or science room which has heavy servicing involved - as much as \$20 000 or \$25 000 would be typical. You get an exceptional problem when you cannot get close to the services and it can be more expensive to extend those services.

Mr Rowland was also asked to comment on the current method of transporting demountable facilities:

CHAIRMAN: How is the transport of demountable buildings arranged? Is it arranged through the Department of Public Works and Services?

Mr ROWLAND: There is a current trucking contract in existence, with TNT I think. It is a State contract that is renewed every couple of years. A request comes from the school to the department; the department agrees that it has an entitlement or otherwise; if it agrees, a building is identified by the Department of School Education to go from school A to school B; a notice goes out; the trucks are booked; and the Department of Public Works and Services arranges for the unbolting and disconnection of the building at the school it is coming from, and for the provision of foundations and services at the school it is going to.

Mr Rowland went on to say that the DSE was currently in the process of updating this transportation method by including it in the new maintenance contracts:

We are proposing to change the method of delivery and attach it to the long-term maintenance contracts. It will be a requirement of the on-site contractor who maintains the building to disconnect it and for the other contractor, if it is going to a different district, to reconnect it, with the Department of Public Works and Services managing the risk on that as an oversight.

The Committee queried whether the current system of contracting for demountable transportation was cost effective:

Mr RIXON: It has sometimes been suggested that a local contractor would be able to shift a demountable building from school A to school B, which might only be a matter of a few miles down the road, more cheaply and more quickly because of waiting times and other issues that are involved. Under the current system, for example, someone is often brought from Sydney or Newcastle to the north coast. That claim has been made from time to time. Have you had any experience of that and could you comment on it?

Mr ROWLAND: I have heard of the claims. It is difficult to move demountable buildings. Even the old system buildings require a table-top truck with small wheels or they exceed the load height. All the contractors' trucks are adapted for

that. Alternatively, one would have to put them on a low-loader, and the new system buildings require a low-loader. My experience so far has been that people seem to believe that you can simply lift up a demountable, put it on the back of any truck or semi-trailer, take it down the road and put it somewhere else. At the very least you would probably be breaking the law in respect of the rules that relate to load height. No-one has ever seriously put it forward as an alternative proposition.

Mr RIXON: The suggestion has often been raised on the north coast where there is quite a deal of movement of houses as well. A number of local contractors are used to moving houses and various other buildings and they understand the provisions of the law quite well. It is something that has caused concern from time to time and I would be interested in your comments.

Mr ROWLAND: I do not have a definitive answer but we are always interested in new procedures and perhaps that will evolve if it is viable.

The Committee welcomes any initiative by the DSE to update the demountable transportation system, which has been cumbersome and slow in the past.

The incorporation of demountable transportation into the new school maintenance contract system will streamline the movement process and may offer significant cost savings.

The Committee believes that it may also offer opportunities to local contractors who have experience in moving residences. This would be a significant improvement on such work being undertaken by capital city based companies.

2.3.5 Refurbishment Costs

The nature of demountables as relocatable facilities places increased stress on both structural and interior components, necessitating regular inspection and refurbishment.

The DSE has a refurbishment program designed to address both interior and external structural issues as well as incorporating new environmentally sustainable design features.

The DSE/DPWS submission to the Committee (s.7) noted that the “refurbishment of a 4 module learning space, including modifications to bring the space up to current facility standards, is costing in the order of \$45 000.”

It was also noted that an average of 75 Demountable General Learning Areas had been refurbished over each of the previous four years.

During the evidence of Mr Zahn, the Committee placed a series of Questions on Notice on demountable refurbishment to the DPWS.

The reply by the DPWS outlined a comprehensive process of refurbishment for a typical 4 Module Demountable Classroom:

- The building is skeletonised down to the steel frame (the roof is removed along with all wall panels, windows, linings, floors).
- The exposed steel frame is sand blasted, painted with zinc enriched primer plus two top coats of acrylic paint. These processes may extend the life of the building for 30-35 years.
- The Module jointing techniques is improved to prevent students picking out the bituminous weather seal.
- The structure is strengthened for both transportation and unusual site conditions.
- A new roof is fixed onto new additional 'c' channel purlins, which create a steeper roof pitch, making the buildings more weather proof.
- New sloping sun louvers are installed replacing the previous horizontal ones, which were more susceptible to wind damage.
- Wall panels, linings and windows are re-installed except those that are no longer serviceable, which are replaced.
- A Practical Activity Area is incorporated into the classroom design to bring the facility closer to the Primary School Facilities Standard requirement.
- New, fire-resistant carpet with underlay is installed, increasing the life of the carpet and the thermal insulation of the floor.
- Ceilings of thin compressed fibre, which often cracked in relocation, are replaced with thicker and stronger material.
- Asbestos lining to the back wall is sealed off with oversheeting. This complies with safety requirements.
- Internal plywood linings are sanded down and repainted.
- Floors are soundproofed by fixing Hebel panels from the underfloor to the ground around the perimeter of the buildings.
- Electrical wiring is upgraded to comply with current Australian Standards. Disconnection and reconnection of wiring between modules is eased by the introduction of a system of plugs and sockets in lieu of connectors and terminal strips.
- Lighting efficiency is increased by the use of reflectors behind the tubes.
- Security of the building is improved.

The Committee also inquired in the Questions on Notice about whether there were different grades of demountable refurbishment.

The DPWS replied that:

- **On-site Demountables** are refurbished at the same time as the rest of the school receives Cyclic Maintenance. Typical on-site work includes basic maintenance such as replacing sub-standard wall panels, windows, internal wall linings or carpet as well as repainting. If extensive maintenance is required then the demountable will be removed from site and the modules separated so that the previously inaccessible steel work can be painted.

The electrical wiring is also upgraded to meet Australian Standards and the floor covering replaced.

- **Off-site Demountables** are either transferred directly on-site or held in a repository at Cessnock Gaol. Prior to any move they are assessed for the scope of refurbishment. This can mean either minor work that can be carried out as part of the relocation to another site or a complete refurbishment.

In addition to replacing worn demountable components, the DSE and DPWS are continually developing and trialing new facilities and improvements to demountable buildings.

The current trials address safety issues such as non-slip paint and Occupational Health and Safety (H&S) issues such as sound insulation and installation of reverse cycle air conditioning.

The issue of incorporating ESD design principles into the demountable refurbishment program was also targeted by the Committee.

In reply to the Committee's Question on Notice regarding the cost of incorporating ESD design principles, the DPWS noted:

This is difficult to assess without carrying out a proper study that would include cost options and cost benefit analysis.

The DPWS suggested that innovative new building materials could be introduced if they proved to be durable:

... new more environmentally sustainable materials could be investigated for introduction into wall, ceiling and floor elements, but these would also have to meet the strict durability and maintenance requirements of transportable school buildings...

The DPWS went on to acknowledge that "thermal comfort" of demountables had been identified as a pressing issue in the recent POEs:

The 1996 Post Occupation Evaluation study indicated a widening thermal comfort gap between the Component Design Range classrooms and demountables.

Consequently it was proposed at the Facility Standards Committee meeting of 18/09/96 to develop a brief to review the design of the demountables in accordance with Passive Solar & ESD Design Principals.

The DPWS also provided the Committee with indicative costs per classroom in implementing ESD design principles, which are contained in Table 10.

TABLE 10: Cost of Installing ESD Features in Demountables

ITEM	COST (\$)
2 Roof Light Strips	1 900
2 Roof Turbos plus damper control gear	1 200
2 Insulation Blanket layers (R1.5 & R2.5) in roof space.	1 000
Air ventilation perforation through eaves and purlins.	500
Period Bell lighting control system	1 500
Water Flow Restrictor Valves	200
Total	\$6 300

The Committee supports advances by the DPWS and the DSE to increase the thermal comfort of demountables to the level of lightweight accommodation.

Submissions to the Committee reported deficiencies in the thermal comfort of demountables, which limited their effectiveness as learning spaces. This evidence is examined in detail in the next section of this Report.

The decision to review the design of demountables in accordance with Passive Solar & ESD Design Principals indicates that the DSE and DPWS have recognised deficiencies in demountable accommodation.

This decision also indicates that there is a preparedness by the DSE and DPWS to rectify as much as possible the ‘environmentally unfriendly’ tag attached to demountables.

The Committee believes that the DPWS, in conjunction with the DSE, should pursue the integration of ESD design principles within the demountable refurbishment program.

Part of this process should be a thorough investigation of those environmentally-sustainable materials which could be introduced into wall, ceiling and floor elements of demountable buildings while still meeting the strict durability and maintenance requirements of transportable school facilities.

2.4 Evidence to the Committee on Demountable Accommodation

The best evidence of the relative merits and failings of lightweight accommodation in NSW schools comes from its users. Ultimately, it is students and staff who must work within these facilities. The Committee received substantial evidence in its submissions and evidence detailing the flaws in demountable buildings.

While all parties concede that the use of demountables is essential for providing emergency

accommodation, there is staunch opposition to the DSE's transformation of demountable temporary accommodation into de facto permanent facilities.

In its submission (s.6), the NSW Primary Principals' Association (NSWPPA) stated:

The NSWPPA acknowledges the need for short term temporary accommodation for students in emergency situations. The provision of temporary accommodation should not be for the long term and adequate maintenance should be provided. Temporary accommodation should be designed to meet the needs of teachers, students and clerical staff who occupy and use these rooms on a daily basis.

The NSWPPA concern over the use of demountables as permanent accommodation was supported by the NSW Teachers Federation in its submission (s.6), which noted that a number of full demountable schools had been installed in high growth areas:

It is essential that schools in high growth areas are catered for with attractive, energy efficient, educationally sympathetic and aesthetically pleasing accommodation. Often over the past two decades the Department of School Education's response to areas of proven expansion demographics in a particular area is the full demountable school. Windsor Park south of Windsor is a particular primary school example. Half of the 12 classrooms are demountables. This scenario is repeated in different schools throughout the state where some have more than 50% demountables.

The NSW Teachers Federation (s.5) noted that this type of school facility sent the wrong message to the population of high growth areas:

The horror of the full demountable school in growth areas can only send messages of impermanency and of education as a transient activity to the population of those areas.

Given what it called the "reasonably predictable characteristics of a population, particularly one in a new residential development," the NSW Teachers Federation (s.5) also queried the inability of the DSE planners to anticipate expanding school enrolments in time to construct permanent facilities:

It is often questionable, however, that the Department of School Education planning cannot anticipate the changes in demographics that would allow construction of buildings to suit rapid expansion of students numbers.

The Committee has discussed the intricacies of planning for both changing enrolment patterns and the provision of adequate school facilities in Chapter 1.

The Committee received consistent evidence about serious flaws of demountable buildings.

In its submission (s.6), the NSW Primary Principals' Association provided the Committee with the results of a survey of 157 principals in June 1996 regarding lightweight school facilities.

The sample represented a balanced proportion of metropolitan, rural, large, medium and small schools across the state.

The survey identified 127 (or 81%) of schools in the survey group as using demountables on site as classrooms. About 67% of principals believed that demountable accommodation was suitable for this purpose. The next most common use for demountable buildings was for administration purposes (34% of schools surveyed) and as specialist classrooms (31% of the schools surveyed).

The survey also addressed perceived deficiencies in demountable accommodation. The results are contained in Table 11.

TABLE 11: Demountables - Survey of Deficiencies

REASON WHY DEMOUNTABLES ARE CONSIDERED DEFICIENT	NO. SCHOOLS
too hot/cold	105
leak in wet weather	86
unattractive	70
unsafe	36
can't support high technology learning	62
cause of community complaints	44
not compatible with existing buildings	74
poor maintenance	66
security	14
noisy	5
too small	2

The thermal dynamics of demountable buildings proved to be the main complaint among the survey group, with 105 respondents identifying this problem.

Leaking between modules during wet weather was identified by 86 respondents as a major demountable deficiency, while 70 respondents were concerned with the unattractive appearance of demountable buildings.

The NSWPPA survey contained in its submission (s.6) included an appendix in which comments from the survey respondents were catalogued.

These comments are indicative of the attitude of users to demountables in NSW schools:

- “School has 22 demountables most leak, heating and cooling inadequate.”
- “School has 23 demountables which are too hot/cold.”
- “Not suitable for Western Region and temperatures above 40°C.”
- “Demountables too noisy, not enough power points, storage, security, lacks privacy.”
- “Can’t modify demountables for disabled students.”
- “No wall hanging space or wet area.”
- “All demountables need to have water connected.”
- “Demountables arrive in poor condition.”
- “Maintenance of demountables poor.”
- “Difficult to commit expenditure to demountables, lost when taken away.”
- “Reluctant to connect demountables to computer network - vandalism, eventual loss of building.”
- “Schools should not be responsible for costs to bring demountables up to standard.”
- “Demountable buildings should have defined ‘shelf life’.”
- “Demountables provide poor public image.”
- “Demountables “cause parents to enrol elsewhere.”

The survey conducted by the NSWPPA (s.6) noted a general consensus about the insufficiencies of demountables:

Principals generally feel that demountables are not satisfactory for long term use as classrooms or administration blocks. The main reasons for dissatisfaction include:

- not sufficiently insulated/cooled for climatic variations;
- poor construction results in leaking;
- design is unattractive;
- unsafe - stairs/flooring, etc;
- poor maintenance regime maintained on these buildings;
- not linked to security systems;
- poor sound proofing;
- work space generally too small.

The Committee found that there were two strands to these critical comments contained in the NSW Primary Principals’ Association survey:

- 1. Demountables have fundamental structural and design flaws which make them poor and potentially dangerous learning spaces.**
- 2. Schools are reluctant to commit scarce resources to demountables because they will be removed.**

These complaints about the overall inferiority of demountable accommodation were supported by other submissions.

In its submission (s.5), the NSW Teachers Federation outlined the main groups of complaints against demountables from its members over the past two decades. These criticisms are quoted in full below:

- The capacity of demountables to cope with extreme temperatures and wet weather. Common problems have related to leaks, in particular into electrical fittings in ceilings and poor wet weather access due at times to the lack of covered walkways.
- Teachers continually note the discomfort of their students accommodated in demountables especially through the summer months. The windows of demountables are inadequate in most climates for the free flow of air. This caused problems with condensation both internally and externally.
- The siting of demountable buildings can cause problems with connections to power on a school site. Lack of water, heating, ventilation and drainage can also impact upon student learning, in terms of other utilities that are essential for a high quality delivery of education.

The NSW Teachers Federation submission (s.5) concluded:

Demountables were identified as having inadequate heating and cooling and being particularly prone to leakage. Inadequate security against illegal entry and vandalism, faulty carpet joints leading to occupational health and safety problems, lack of adequate water, power, ventilation and drainage make demountables poor candidates in the permanent occupancy stakes.

Numerous individual problems with demountables were chronicled in submissions received by the Committee, mostly relating to the structural flaws inherent in demountable design and the inability of demountable buildings to deal with climatic extremes.

The Committee observed this problem first hand during its site inspection of the NSW North Coast when it visited Pottsville Beach Primary School. In the demountable library, gaps were clearly visible between modules and one wall suffered serious leaking during storms, which had caused substantial book damage. There were also reports of sparks emanating from power points during storms.

In its public hearing, the Committee questioned Mr Dave Muddiman about problems with leakage in demountables on the North Coast. It found that the DSE had developed a solution to this problem by placing a better roof over the demountable unit:

Mrs BEAMER: The Committee has received many submissions that criticised demountables because of the unsuitability of climatic extremes. How have

demountables been adapted to the north coast? Are you aware of the cost involved and any associated hindrances?

Mr MUDDIMAN: Demountables were developed to meet an emergency situation. Unfortunately, the design certainly has its shortcomings. The fact that it is a metal building obviously makes it very hot in climates such as that experienced on the north coast. The other major problem is that they inevitably leak. The modules are joined with a cap over the joints and mastic between the joints. During a long dry period the mastic dries out and with the first rain it leaks. In the meantime the box gutters, which are not easily accessible from outside the building without actually getting onto the roof, fill with leaves and then the water overflows into the roof area and into the building. It is not uncommon to have reports of water coming out of power points when a long period of dry weather is followed by wet weather. It is a real problem.

We developed not actually a fly roof but a roof that goes over our demountable unit. The demountables are designed with a box gutter and a flattish roof with very little drop. We designed a roof that went over the whole demountable unit with an external conventional gutter. We found that with that conversion the buildings could still be moved easily, it overcame the problem of leaks and to some extent overcame the problem of heat because the false roof created an insulating area between it and the original roof.

ACTING CHAIRMAN (MR RIXON): How high was the fly roof above the original roof?

Mr MUDDIMAN: It came to only about a foot above the original roof. It was still low enough to allow for easy transportation of the modules under bridge restrictions. That modification cost between \$3,800 and \$4,000. We usually did that only when we struck a serious leak problem. Quite often it was cheaper to do that than try to find the leak. Trying to stop demountables from leaking was like looking for the proverbial needle in the haystack. We also experimented with a proprietary paint material that was supposed to reduce the temperature by six to eight degrees inside buildings with metal roofs. We tried that on buildings at Bonalbo just before the regional office was closed. We never got the results. (45)

While reiterating criticism that demountables were prone to leakage, the submission from the NSW Secondary Principals' Council (s.9) concentrated on the issue of demountable maintenance. The submission noted that schools did not spend funds on maintaining demountables because they could be removed at short notice:

Schools are reluctant to spend "school funds" on demountables because they could be taken away on short notice.... Consequently demountables are frequently left without blinds and curtains. Carpet is often left in poor condition rather than replaced. The learning ambience in many demountables suffers because of this. Poor drainage from the flat roof is often a problem which can lead to water entering demountables and damaging insulation or carpet. In some cases, this leads

to safety concerns with water near power points.

The Committee raised this point with Mr Rowland of the DSE during his evidence:

Mrs BEAMER: Submissions to this Committee have argued that schools do not spend money on maintaining demountable buildings. They believe that they are a short-term proposition when the fact is they are not; a lot of them will be there for quite some time. Are there any strategies in place to deal with that problem?

Mr ROWLAND: Yes, new maintenance contracts to be called for over the next six to eight weeks—the first of the tenders will be called next week or the week after and they will all be in place by August—require all demountables to be maintained to a pre-determined standard. (12)

In addition to the complaints of industry associations, the Committee received evidence from individual principals and school councillors.

The Committee selected submissions from the Principal of Menai Primary School, Mr Trevor Somerville (s.2), and the Council President of Menai Primary School, Ms Sue Summerfield (s.4), as representative case studies of the response of users to demountable accommodation in NSW schools.

In his submission (s.2), Mr Somerville noted the inability of demountables to cope with extremes in weather:

They are unfit for children and teachers in the extremes of summer conditions. Nothing short of airconditioning can ameliorate these hot conditions. They are ugly and detract from the appearance of the school and the surrounding environment. They invariably leak in wet weather. The stairs are particularly dangerous (worse in wet weather).

Mr Somerville considered the current conditions of demountable buildings to be detrimental to student learning:

I firmly believe that the educational opportunities of those children in demountables are less than those in permanent buildings.... (There can be up to a six degree difference in temperature between permanent and demountable buildings).

Mr Somerville considered airconditioning to be the “minimum requirement to make them places where children and teachers can work in reasonable conditions.”

Mr Somerville concluded that “the community is aware of the substandard nature of demountables and they reject them.”

This contention was supported in the submission (s.4) of Ms Sue Summerfield, Council President for Menai Primary School. Ms Summerfield stated that demountables had an adverse impact on learning during the crucial infants and primary periods of school education:

... it is logistically impossible to ensure that students are not forced to spend most of their infants and primary education in sub-standard facilities. It is therefore one of our greatest concerns that we could unwittingly be discriminating against some pupils in not providing suitable accommodation.

Ms Summerfield outlined the way in which students were cramped into cooler brick buildings in hot conditions because demountables were unsuitable for teaching:

Our objections to demountables are numerous. Anyone who has spent time in a demountable on a hot summer's afternoon would be all too aware that the pupils present in that demountable are being denied access to quality education. The heat is so unbearable that on several occasions at our school it has been found preferable to cram several classes into a brick building rather than endure the heat of the demountable.

Ms Summerfield reiterated Mr Somerville's call for airconditioning to be fitted into demountables.

Ms Summerfield also alerted the Committee to wet weather problems with exterior walkways: "the stairs have proven dangerous especially in wet conditions and many of the demountables leak badly during wet weather."

The Committee is concerned about the use of demountable buildings as de facto permanent accommodation in schools around NSW.

In its submission to the Committee (s.5), the NSW Teachers Federation identified a number of NSW schools where 50% of the school facilities were demountable buildings.

These schools are almost always located in new development areas, where a lag in the provision of community services is a continual problem.

The current stock of demountable buildings will remain in service to meet the needs of the Core Plus system.

However, no further demountables of the kind currently used in the NSW education system should be purchased.

The DSE envisages the gradual replacement of demountable buildings with CDR lightweights where enrolments remain high.

In addition, new generation relocatable lightweight buildings designed by the private sector

to meet Schools Facilities Standards may offer a suitable long term replacement to existing demountables.

The Committee also looks to the new Urban Management Committee of Cabinet to provide better coordination and more timely provision of infrastructure in urban development areas.

The Committee believes that the DSE's caution in the provision of permanent facilities for developing areas is warranted.

The nature of new developments - particularly on the NSW North Coast - makes it difficult to accurately predict the take-up rate of land, the age structure of the population and hence future enrolments.

The Committee witnessed the difficulties of urban growth areas first hand during its site inspection of schools on the NSW North Coast.

For example, Pottsville Beach Primary School has experienced an enrolment boom during recent years and outstripped available permanent facilities. Ongoing problems with site acquisition for a new school meant that there were fourteen demountables on site at the time of the Committee's inspection. Fortunately, a completely new CDR school is being constructed for 1997.

The Committee views the DSE Demountable Refurbishment Program as providing the opportunity to address the rectifiable problems identified in submissions such as leakage and walkway safety.

The Committee was particularly impressed with the ingenuity of DSE officers on the NSW North Coast, who had overcome leakage problems in demountables by installing an additional roof canopy over the demountable unit.

This innovation would be particularly useful in demountables which are being used to house perishable items or electrical goods, such as libraries or computer rooms.

The Committee is confident that other innovative solutions will be found given the recent track record of the DSE and the DPWS with regard to new facilities standards, comprehensive asset management and a better maintenance contracts system.

The Committee investigates some possible solutions later in this Report. Relocatable lightweight buildings are assessed in Section 2.8 and shared facilities at Section 2.9.

RECOMMENDATIONS

7. **The Committee endorses the current Department of School Education policy of not purchasing further demountables of the kind currently used in the NSW education system. This policy should continue.**
8. **The Demountable Refurbishment Program be upgraded to address problems with leakage and walkway safety.**

In particular, the use of a portable roof canopy over demountable buildings on the NSW North Coast to stop leakage should be considered for areas of high rainfall, especially where they are being used as libraries or computer rooms.

2.5 Comparison of Lightweight and Demountable Buildings

One of the primary objectives of the DSE and DPWS is to ensure that the permanent school facilities used in the NSW education system offer best value for money in terms of construction, maintenance and educational service. To this end, all lightweight building designs used by the DSE and DPWS aim to facilitate efficient, cost effective construction while meeting industry and legislative standards.

In evidence before the Committee, Mr Zahn of the DPWS noted that the CDR represented a philosophical shift in school facility construction:

On costings, Public Works has gone from being the most outlandish builder and designer in Australia—we have won lots of awards, but we are not winning any awards at the moment because of the CDR. A lot of our internal architects are not happy at all. As far as producing a product that is fast, efficient and serviceable so far as the educational environment is concerned, it is an unbelievable product.... As far as being an economic product is concerned, you can not get any lower. If you look at the project home price, which is what we were comparing it to before, that is about \$500 a square metre in today's terms. This building is \$675 a square metre. The windows are twice as thick and it has all the other features that I talked about before. We used to build schools for more than \$1,000 a square metre, and we have brought it back to \$675 a square metre. (58)

As construction methods for lightweight buildings equate with dwelling construction techniques, project home construction rates are used as benchmarks for evaluating the cost effectiveness of current standards.

A comparison of demountable, CDR, Kit and Project Home construction costs is contained in the

Table 12.

TABLE 12: Comparison of Costs for Lightweight School Buildings and Project Homes

Type	Cost per Homebase	Gross floor area	Rate (per m ²)	Features
Demountable	\$78 470	95m ²	\$826	Adjacent covered walkway
CDR	\$82 416	136m ²	\$606	Attached covered walkway and COLA
Kit	\$75 057	127m ²	\$591	Attached covered walkway and COLA
Project Home	NA	Varies	\$622	Average rate adjusted to include school type inclusions

Source: DSE Submission (s.7)

The average construction cost for a standard Project Home based on published price lists is \$478 per square metre.

To compare this cost with school building rates the following additional rates per square metre need to be considered:

- substructure preparation on typical school site \$29
- floor finishes - carpet, vinyl \$34
- light fittings school standard \$26
- Holland blinds \$ 6
- windows \$ 7
- fans, turbo vents, roof lights \$12
- gas heaters \$14
- pinboard wall linings \$ 8
- structured cabling \$ 8

These additional items bring the total cost to \$622 per square metre.

A comparison of the cost of demountable, CDR and Kit school facilities with project home construction costs indicates that a high level of competitiveness has been achieved in NSW.

However, the basic cost of facilities is not a measure of the quality of those facilities or their lifetime costs.

A number of additional issues must be considered in any comparison of permanent and demountable lightweight school facilities.

The Committee has consolidated these issues under the following headings: design; approval and construction; and thermal comfort.

Design

Demountable buildings are designed as temporary accommodation. The nature of demountable buildings means they are built for structural soundness rather than attention to design features. Indeed, demountables have not been purpose-built as school facilities.

Demountable buildings can accommodate multiple movements without fabric deterioration. They can be quickly adapted to different site locations because they have been fabricated in a factory and incorporate a standard set of drawings to construct the building envelope.

The site is customised through the construction of piers on which the demountable modules are placed. Trees are removed if necessary and walkways provided. The design of demountables enables the DSE to place them on a school site as quickly as they can be relocated.

CDR and Kit Lightweight permanent buildings have been designed to different standards and as such may require a greater degree of customisation to suit the location. Depending on the geography of the site, the substructure of the CDR or Kit building may alter quite markedly.

The Committee noted in Section 2.2.1.1 that the CDR Post-Occupancy Evaluations for 1995 indicated a high level of approval for the sensitive manner in which the DSE and the DPWS had arranged site layouts.

In comparison to the new generation lightweight school facilities, the design of demountables is restrictive. Demountables lack a number of essential features incorporated into the CDR and Kit buildings such as disabled access, withdrawal areas, computer spaces and storage. These design features are predominantly aimed towards enhancing comfort conditions within CDR and Kit buildings.

Permanent lightweight buildings were consistently preferred to demountable accommodation in submissions to the Committee.

The submission of the NSW Teachers Federation (s.5) reported:

Overall, principals and teachers were ecstatically happy with their lightweight construction buildings. When compared to demountables, staff regarded these buildings as permanent rather than transportable and far superior to demountable student accommodation. It was reported to the federation that these buildings can be constructed as modules and therefore are potentially transportable.

The NSW Teachers Federation submission (s.5) continued:

All staff surveyed commented upon the space available in lightweight buildings versus demountables. In educational terms they were seen to be far superior to demountables for flexibility of the classroom space, withdrawal area/computer space and for the additional space that could be arranged in different ways to suit

the education of children concerned.

These findings were borne out in the survey conducted by the NSW Primary Principals' Association, which was included in its submission to the Committee (s.6).

The Committee will discuss further advances in school facility designs in Chapter 4.

Approval and Construction

The construction of new school facilities represents a period of potential disruption to educational activities. It is apparent that the faster school facilities can be constructed, the smaller the potential for disruption.

The *Environmental Planning and Assessment Act (1979)* imposes legislative requirements on approvals for school facilities.

The fabrication of demountable buildings to a standard structural design means that a Development Application (DA) is not required to be lodged for installation on a school site in the event of urgent need or emergency. DA approval is required, however, when demountables are established on new sites. On average, a straightforward approval can be processed in two months.

The construction period for a permanent lightweight building may take up to six months from the contractor taking initial site possession to the acceptance of handover. During this time, site excavation will render the site unusable and construction noise will impact on student learning.

While CDR and Kit buildings are both relatively simple designs and as such should not pose any problems to construct, they do involve the use of a variety of specialist wet and dry trades to achieve completion.

An additional factor which should be considered is the frequency of deliveries to the site. With CDR and Kit buildings, materials are delivered and components fabricated on site. The frequency of these deliveries is high compared to the number of deliveries required to install a demountable.

The module design of demountable buildings impacts less upon school activities. The pre-fabricated modular design of demountables enables them to be assembled within a week of arrival on site (including external works). The only site works required for demountable buildings is the construction of brick supports, and minor service connections for electricity and gas.

Thermal Comfort

Student comfort is a crucial education issue. A good learning environment in which students can exercise maximum concentration requires protection against the elements. In submissions to the Committee, the issue of thermal comfort and demountable performance was raised on numerous occasions.

The ability of demountable buildings to cope with a variety of climates is generally acknowledged

as being vastly inferior to lightweight school facilities. The submission received from the DSE (s.7) conceded as much when it acknowledged that "thermal comfort conditions in demountables are not always acceptable."

The DSE submission also noted that weather penetration in demountables was a problem:

Over the course of a 50 year lifetime statistics indicate that an average demountable building would change its location six times. The reality is that when demountables are disconnected and reinstalled there are stresses put on the fabric of the building. This can result in occasional failures, particularly in the roof covering and the sealing between modules, which allow rain and wind to penetrate the envelope.

The Committee received considerable evidence of these flaws in demountables, which were documented in the previous section.

In comparison, the design and construction of CDR and Kit lightweight buildings provide superior protection against changing climatic conditions.

The construction of lightweight buildings incorporates materials which provide better durability and insulation than the materials used in the construction of demountable buildings.

In addition, CDR/Kit lightweights incorporate a number of design features aimed at improving thermal conditions. These features include the use of wind driven roof ventilators, high ceilings and larger windows to improve the ventilation characteristics of the classroom. Roof spaces are generally insulated to reduce the amount of heat entering the classroom in summer and to limit heat loss in winter.

Permanent lightweight facilities such as the CDR and Kit buildings are clearly superior to demountables in the crucial categories of design, quality and thermal comfort.

They are also much cheaper in terms of cost per square metre, being comparable with project home construction costs.

The DSE and the DPWS should be congratulated on achieving high quality permanent school facilities which can be easily and economically constructed.

The only advantage to demountables is the speed with which they can be brought into operation.

This is in keeping with their primary role in the NSW education system, which is to provide accommodation during enrolment surges or emergencies.

2.6 Life Cycle Costings

The life-cycle cost of a building takes into account the cost of construction, annual operation costs, ongoing maintenance and eventual disposal costs.

The DSE currently uses life-cycle cost modelling as the theoretical methodology to determine the total cost of lightweight buildings over their usable life.

Life cycle cost modelling includes planning, design, construction and maintenance of school facilities.

Controlling initial construction costs is an important part of cost efficiency. However, long term maintenance costs must also be considered. Put simply, it is counterproductive to construct a cheaper building if it is going to cost substantially more to maintain over the term of its usable life.

The maintenance cost of school facilities is an essential component of the life-cycle costing process. Those school facilities constructed from cheaper, less durable materials will cost more to maintain in the long term.

In its submission to the Committee (s.5), the NSW Teachers Federation argued that the relative costs of lightweight buildings should be measured over their life cycle rather than just in terms of initial construction costs:

It is our belief that lightweight buildings ultimately are less costly in the long term than demountables because of: energy efficiency; less construction costs - lightweight frames; less problems because of geographical closeness of contractor to the site - local builder reputations are important; the flexibility of working with a builder who can adapt small but crucial items to the education process - eg. siting of power, TV and computer points; less maintenance costs.

The submission to the Committee from James Hardie Building Systems (s.8) reiterated this argument:

... the initial construction cost...is often a determining factor as to which form of construction (is) adopted. This is despite the facts, which show that the long term costs taking into account maintenance and operational expenses, can result in a higher total cost solution.

In its submission to the Committee (s.7), the DSE presented a table of projected life-cycle costs (including general maintenance) over 50 years for the various forms of lightweight buildings currently used in NSW schools.

Table 13 on the next page outlines these costs.

TABLE 13: Net Present Value Costs of Primary School Homebases Over 50 Years

Building Type	NPV Cost over 50 yrs	Area (m ²)	NPV Cost over 50 yrs/m ²
CDR	\$201 956	136	\$1 485
Kit	\$184 899	127	\$1 456
Demountable	\$154 112	95	\$1 622

Note: CDR and Kit costs include attached covered way and COLA allowance.
Demountable costs include adjacent covered way.

The DSE notes with reference to the above table that:

...no allowances were made for accelerated fabric deterioration resulting from vandalism, harsh environments or mechanical damage. The operational costs of utilities and the residual values have not been included.

From the information contained in Table 13 it can be determined that the Net Present Value (NPV) cost over 50 years for demountable buildings (\$154 112) is lower than for CDR (\$201 956) and Kit (\$184 899) buildings.

What should be noted, however, is that NPV costs **per square metre** over 50 years indicate that the demountable becomes the most expensive facility (\$1 622 m²), followed by the CDR (\$1 485 m²) and finally Kits (\$1 456 m²).

Life cycle costing should not be confined to the tangible costs of constructing and maintaining school facilities. It should also identify the environmental cost of facilities.

Environmental impact includes the impact of construction on the site, the amount of energy expended in the construction process and ongoing operational costs such as lighting, cooling, and heating.

The Primary School Facilities Standard notes with regard to heating that habitable spaces should be provided with space heating of a suitable type and quantity. DSE policy requires that the choice of heating methods be decided by a life-cycle costing analysis.

The Primary School Facilities Standard notes with regard to cooling that circulating fans should be provided in all habitable space unless otherwise indicated. Currently, air conditioning is required only in those schools affected by Public Sector Management Regulation 37 or west of the 33°C isotherm.¹

¹ The 33 degree isotherm is a heat contour devised by the DSE for determining heat stress on students. It runs through NSW to the west of Tamworth through Gunnedah and Dubbo, West Wyalong and Griffith.

The environmental impact of demountable buildings in terms of site impact is relatively negligible. Because of the module construction of demountable buildings, they only require relatively minor site works prior to assembly.

However, the environmental cost of demountable buildings is quite different if energy consumption is considered. Poor thermal insulation in demountables necessitates the use of some form of heating (usually electric) and cooling (circulating fans and air conditioning).

The reliance upon this kind of non-passive technology for heating and cooling results in a significant use of non-renewable resources with associated costs, especially over a NPV period of 50 years.

By contrast, the net environmental cost of lightweight buildings is much less than demountables when consideration is given to energy efficiency.

The majority of the DSE Capital Works Program is governed by the DPWS' environmental policies, which are based on ESD principles. Two key objectives of ESD are to eliminate unnecessary waste and to inhibit the flow of pollutants into the natural environment by better planning and more efficient use of natural and manufactured resources.

With regard to energy consumption, CDR lightweight buildings have been designed to enhance energy efficiency through the incorporation of passive design characteristics. The inclusion of Passive Solar design principles has facilitated simple solutions to the problem of ventilation, insulation and sunlight penetration.

The CDR lightweight has a number of features which improve thermal efficiency. These include the use of cross ventilation in classroom designs, polycarbonate roofing strips to allow natural light to enter the classroom, rooftop turbo vents, insulation under the roof and on top of the ceiling, and ceiling fans to improve thermal comfort conditions.

Both the CDR and Kit buildings are excellent facilities in terms of energy efficiency and maintenance costs. They are clearly superior to demountable buildings.

They have been designed to minimise maintenance costs from user damage. They also incorporate passive energy innovations.

These features offer significant life cycle cost savings.

However, the 1995 Post-Occupancy Evaluation surveys conducted by the DSE indicated that poor quality fittings and workmanship may be a problem in some comparatively new CDR school facilities.

The Committee is certain that the DSE will work with this data to upgrade the CDR where necessary.

The DSE and the DPWS are also aware of inefficiencies in the design of demountable buildings and have identified insulation as one of the primary objectives of the Demountable Refurbishment Program.

By targeting insulation, the DSE/DPWS should be able to improve the passive cooling and heating characteristics of demountables, thus reducing expenditure on non-renewable resources and improving energy efficiency.

The Committee outlined indicative costs for the incorporation of a number of ESD principles in demountables when discussing the Demountable Refurbishment Program in Section 2.3.5.

The Committee elaborates on the environmental sustainability of school facilities in Chapter 4.

2.7 Compatibility with Existing School Facilities

The Committee has already outlined the history of school facilities in NSW, noting that the asset base of the NSW school education system includes buildings that are now over one hundred years old. The average age of school facilities in NSW is approximately 30 years.

The simple and austere layout of these older facilities reflects the limited educational requirements of past eras, which focussed on delivering basic learning requirements to the school aged population of NSW.

It is sometimes difficult to incorporate new facilities designs into these stolid school layouts.

The compatibility of new facilities with existing facilities, however, plays a significant part in gaining community acceptance and ensuring their utility.

The submission received from James Hardie Building Systems (s.8) noted that community reaction to both demountables and lightweights was often prejudiced by the permanence associated with older style facilities. These facilities were seen as a "poor substitute for older style school facilities" despite many superior design features.

This submission also noted that both demountable and lightweight buildings could be made to integrate with older facilities through skilful design and the sympathetic use of materials:

There has been little compatibility in the design of demountables. However, there is no reason why a demountable or lightweight building cannot be made to appear aesthetically compatible with older style insitu facilities. It is purely a matter of skilful design. Integration can be also established by sympathetic use of materials in the new facilities which reflect the existing buildings.

The compatibility (or incompatibility) of demountable buildings with existing school facilities has been the subject of commentary by the majority of submissions received by the Committee.

Given that the original rationale behind demountable accommodation was to provide emergency and short-term accommodation, no design requirements were originally incorporated into them, let alone any notion of integration with existing facilities. The design and construction of demountables was solely directed towards the development of an easily transportable functional facility. This meant that the emphasis was on robustness and mobility.

The metallic finish and square shape of demountables is not compatible with the majority of in situ school facilities across NSW.

This fact was noted in submissions to the Committee collected at 2.4 in this Report. For example, Ms Sue Summerfield, President of the Menai School Council (s.4) regarded the appearance of demountables as "aesthetically unattractive" and argued that "demountables detract from the overall appearance of our school." The submission received from the NSW Primary Principals' Association (s.6) stated:

Principals generally feel that in many instances the design of demountable/lightweights is incompatible with existing buildings and is a major source of community complaint and concern.

The same aesthetic and functional problems are not experienced with permanent lightweight buildings.

The traditional design of CDR and Kit lightweight buildings and the use of sympathetic construction materials enables them to blend with existing facilities at the majority of primary schools in NSW.

The CDR lightweight has been designed to resemble traditional school facilities through the incorporation of a peaked roof, twin verandahs, brick veneer construction and large windows. If need be, the design of the CDR lightweight can be customised if modifications are required to enhance compatibility with existing facilities.

The submission from the DSE/DPWS (s.7) outlined how the Kit lightweight has been designed to be compatible with older style buildings, especially in small rural schools:

Kit buildings are specifically designed with small rural schools in mind. The architecture is complementary to older buildings, and the scale, colour scheme, roof pitch and materials complement older style accommodation.

The scale of kits is such that they are not intrusive. The same buildings fit well with older urban facilities, and sensitive design links these new lightweight buildings with older heritage style architecture.

The majority of submissions supported the construction of lightweight facilities as additions in NSW schools. The general consensus on the use of lightweights was perhaps best summed up in the submission from the NSW Teachers Federation (s.5), which noted:

Whether the buildings were built on a pad or on piers all principals surveyed remarked upon the effectiveness of the buildings, sympathetic design in fitting with existing buildings, their energy efficiency through insulation and venting of roof cavities, space accommodation, storeroom and flexible use for wet areas.

The submission continued:

All principals who were interviewed in the New South Wales Teachers Federation survey announced that they were happy with:

- the high ceilings;
- verandahs on both sides;
- toning in with existing buildings;
- the brick/mainly Hardiplank clad building were seen as most appropriate to the mainly north coast conditions;
- all principals commented on the match to older style corrugated iron roofed buildings to the new zinc dipped 'zincalume' roofed new constructions.

The Committee believes that the designs of both CDR and Kit lightweight buildings are compatible with existing school facilities.

This was the general thrust of submissions to the Committee.

The Committee also observed the successful integration of new and old facilities during its site inspection of Terranora Primary School on the NSW North Coast. This school combines a core of traditional school facilities with a large group of Kit buildings (North Coast Kit design) and a new CDR hall with COLA.

The successful combination of Kit, CDR and traditional facilities on the spectacular natural site of Terranora Primary School is testament to the compatibility of the lightweight school facilities developed by the DSE.

2.8 Relocatable Accommodation

The Committee investigated the viability of utilising Relocatable Buildings in the NSW education system as an alternative to demountable, CDR and Kit lightweight buildings which addressed all aspects of school facility planning, design and construction.

The primary difference between the new relocatable lightweights and previous lightweights is that they have been specifically designed for use in schools and therefore meet school facilities

standards.

The key to their success is gaining community acceptance, which has been such a problem with previous types of demountable school buildings. In its submission to the Committee (s.8), James Hardie Building Systems noted that:

... the solution must incorporate the social acceptance associated with insitu built structures plus the flexibility, relocatability and cost effectiveness associated with demountable buildings.

As part of the process of assessing relocatable lightweights, the Committee conducted a site inspection of Holy Spirit Primary School at Nicholls in the ACT. This school is entirely constructed of relocatable lightweights.

Relocatable lightweight buildings are factory fabricated and delivered to the prepared site.

This reduces site disturbance and controls many of the adverse environmental impacts of construction.

They are flexible to the point of removing and replacing individual building elements. For example, the framing system incorporated within the James Hardie relocatable allows for the interchange of wall facings, windows and doors.

They incorporate a steel frame construction complete with impact resistant internal wall linings and composite timber flooring. Windows are constructed from heavy duty aluminium with 5 mm thick glass, which also improves insulation.

These features meet the NSW Primary School Facilities Standard in terms of floor, wall and ceiling insulation.

Relocatable lightweight school facilities use many of the materials currently being used in lightweight school facilities in NSW schools including:

- Moulded sheet materials.
- Exposed steel, including bracing.
- High impact resistant wall and ceiling linings.
- Modular panel construction with expressed joints.
- Hi-tech panel finishes with reduced maintenance potential.
- Specialised wet area partitioning.

The design, documentation and construction process for relocatable buildings is considerably less than for permanent lightweight buildings because the approval process can be conducted concurrently with the factory construction phase.

The process of manufacture and installation can be completed within four months.

Maintenance costs are reduced by efficient design and the use of innovative, alternative materials. For example, the James Hardie relocatable buildings utilise materials which have been selected to minimise ongoing maintenance costs including:

- Fibre cement or plasterboard.
- Ceramic tiles in lieu of bricks.
- Heavy duty window and door frames.
- Hard wearing cloth finishes (carpet) as an alternative to paint finishes on walls.
- Full walls of fabric-covered pinboard in lieu of paint finishes.
- Provision of a spare parts catalogue to minimise costly site maintenance visits.

Relocatable lightweights are designed and built to facilitate high technology planning. They permit economical fit-out of high technology facilities in the factory. The framing structure of relocatable buildings also allows for a greater degree of access and adaptability for any additional fit-out at a later stage. The Committee looks at high technology learning in greater detail Chapter 3.

The environmental benefits of relocatable lightweights include:

- Improved material usage and energy efficiency resulting from the concentration of building activity in the factory rather than on site.
- Greater opportunities for re-use and recycling materials.
- Better waste management and disposal practices both in the manufacturing process as well as at the end of the life of buildings.
- The ability to incorporate a range of wall, flooring, window and wet area systems to achieve varying requirements.
- The use of fixing techniques which enable future modifications on-site when new materials/products emerge and need to be incorporated

Relocatable lightweights have been designed to facilitate effective passive cooling through cross ventilation and insulation.

The use of energy-efficient options reduces the need to rely on the non-renewable power resources which are required for air conditioning units and heaters.

Further, they can be constructed so that their design criteria takes into account the need for recycling.

Case Study - Holy Spirit School, Nicholls, ACT

The Committee inspected Holy Spirit Catholic Primary School in the rapidly expanding suburb of Nicholls, ACT.

This school is constructed entirely of James Hardie relocatable lightweight buildings.

It has been developed as a joint school facility by the ACT Department of Education and Training and the Catholic Education Office (CEO). The Committee considers the concept of shared facilities in the next section of this Report.

The layout of the school is based upon a central access spine from which each block of classrooms projects.

This layout enables classrooms to be orientated to the north east to catch the sun during winter but to provide protection from the heat of summer. Verandahs have been included to provide additional protection during summer and student space during wet weather.

A groundplan of Holy Spirit Primary School is contained at Map 4 of the Report.

Internally, the ceilings are sloped to permit warm air to escape during summer. Windows are located to enhance cross ventilation. Heating is provided by an externally vented gas heater to each room, while there is insulation in the floor, walls and ceiling.

Part of the requirement for the construction of the Holy Spirit Primary School was similarity of appearance to permanent facilities at the adjacent Nicholls Public School. To gain the effect of a permanent facility, the external walls are constructed of mini-brick cladding.

The school itself is constructed entirely from James Hardie relocatable modules, which were prefabricated at a factory in Adelaide.

They include steel frames and compressed fibre cement boards and brick tile cladding. The modules are fully fitted and incorporate thermal and noise insulation.

The school has been constructed in two stages to cater for the projected enrolments detailed in Table 14.

TABLE 14 - Projected Enrolments at Holy Spirit Primary School, ACT

Year	Stage of Construction	Enrolment Nos.
1995	Stage 1 Construction	-
1996	School opens	270
1997	Stage 2 Construction for occupation in 1998	412
1998		448
1999		594
2000		672

The construction of the first stage of Holy Spirit Primary took six weeks with 54 semi-trailer

loads to transport and fully install the relocatables on site.

Site preparation required the installation of simple footings, provision of services (sewer, stormwater, electricity, telephone and gas), grading, paving and landscaping. The modules were being assembled in the factory simultaneously.

Holy Spirit Primary has been designed to be relocated once the functional life of the school has ceased. It is anticipated that this will occur in 15-20 years.

The Committee received evidence on relocatable lightweight school buildings from both Mr John Kimball, Market Development Manager for James Hardie Industries, and Mr Tony O'Donnell, Planning Officer for the ACT Catholic Education Office.

Mr Kimball expanded on some of the information contained in the James Hardie submission.

He confirmed that the James Hardie design specifications were compatible with NSW Primary Schools Facilities Standards for permanent lightweight buildings. He added that the DPWS and James Hardie had worked independently towards the same solution:

This is a brochure from the Department of Public Works and Services. James Hardie has been approaching this from a different angle independent of Public Works, but it appears that we have come up with a similar answer and we both want the same thing. All we say is that we should take it one step further because the trick is relocatability. The industry cries out for that. You can incorporate all the socially acceptable aspects of the building in a correct manner so that the community is happy, but without relocatability you have not got what you need.

On the next page the brochure displays the component design range of interchangeable walls and roofing systems which James Hardie has also been working on and considers to be part of the solution. The design shown at the bottom of the last page of the department's brochure is almost identical to the design that Committee members saw at Nicholls. It is a design that we consider to be functional. It does not have to be the only design. It is interesting that the department and James Hardie have independently come up with a very functional design.(21)

The Committee was interested in the attitude of the DSE towards the concept of relocatable lightweight buildings and raised the matter with Mr Rowland during its public hearing.

Mr Rowland responded positively to the concept:

I am interested... in exploring some dimension that sits between permanent buildings and the existing demountables, if that dimension exists. I know that someone from Hardie's is to appear before the Committee and I have seen their building in Canberra. For some years we have explored the extent to which off-site construction can produce good buildings at a reasonable price. We have never found the solution, but that does not mean to say that the Hardie's

solution or something similar is not appropriate. (12)

Mr Rowland went on to say that the DSE was considering a trial in which relocatable lightweight buildings would be added to a small school in one of the new urban growth areas of Sydney which will experience a sudden enrolment surge in a few years:

We have in mind one school at which the population will be reasonably large for a few years and then become very small or the school will close. Perhaps the most appropriate thing would be to use this kind of building—which will give an environment of some substance and reasonable comfort for the next 10 or 15 years—and, after the population has declined, take the buildings away and keep the school because it is part of the history of the community. I cannot do that with permanent buildings and it would be a long haul to do it with the existing type of demountables. There is room for that strategy as long as it can be done in a cost-effective way. We are certainly open to it. In fact, we are drawing up specifications along those lines at the moment, to test the methodology. (12)

The Committee considers relocatable lightweight school facilities to be a possible solution to the problem of enrolment surges in NSW schools resulting in significant numbers of demountables being deployed.

The specific development of relocatable lightweight buildings to meet school facilities standards means that they are high quality learning spaces which may be more acceptable to the community than traditional demountables. As the existing stock of demountables reach the end of their usable life, relocatable lightweights may provide a suitable replacement.

The Committee is encouraged by the fact that the DSE is already looking at ways of trialing relocatable lightweight facilities if they are deemed appropriate after further analysis.

RECOMMENDATIONS

- 9. The Department of School Education undertake further analysis of relocatable lightweight school facilities being developed by the private sector with the goal of conducting a trial of these facilities if it is deemed appropriate.**

Relocatable lightweight school buildings which have been specifically designed to meet Schools Facilities Standards may prove invaluable as a replacement for the existing stock of demountable buildings as they reach the end of their life-cycle.

2.9 Shared Facilities

The Committee's site inspection of school facilities in the ACT included a tour of an innovative educational concept between the ACT Department of Education and Training and the Catholic Education Office - Archdiocese of Canberra and Goulburn (CEO) to share facilities between two primary schools at Nicholls in the Gungahlin development precinct. The schools are Nicholls Public School (operated by the ACT Government) and Holy Spirit Primary School Nicholls (operated by the CEO).

The Committee examined this concept in detail to determine its applicability to the NSW school system. The Committee was particularly concerned about processes to realise this concept.

The ACT shared facilities concept was proposed by the ACT Government in 1992. The ACT Department of Education and Training and the CEO agreed to set aside land in 1992-93. In August 1993, the CEO formally advised the ACT Minister for Education and Training that it supported the concept of a joint venture at Nicholls. From 1994-95, regular meetings were held to develop the project. The ACT Schools Interagency Coordination Group assisted in this process. This group included representatives from all major government agencies and institutions involved in planning school facilities in the ACT.

In principle support was given for the following joint facilities at Nicholls:

- Parking areas
- The resource centre and library
- A general purpose hall including canteen and multipurpose spaces
- Playing fields including an oval, which was to be fully funded by the ACT Government.

A written agreement was formulated which focused on legal responsibilities, insurance, building and public liability, management of facilities, repairs and maintenance, employment of staff in joint facilities, lease arrangements and ownership.

A financial agreement was reached to construct shared facilities on the basis of 53% government funding and 47% CEO funding. The CEO share was to be paid on the following basis: 10% deposit at the date of occupation and repayment of outstanding principal over 10 years.

The architectural brief for both the CEO and ACT Government stand-alone facilities required that they were complementary to the shared facilities. The education complex was designed so that the stand-alone facilities were located on either side of a central spine of shared facilities.

Consultant architects were engaged to prepare designs from the brief prepared by the clients, undertake final sketch plans and provide a cost detailed estimate of the total project. The ACT Government approached John Hindmarsh Constructions to act as project managers. They called individual tenders for all quotes and tenders. This method of construction produced a final cost of \$2.55 million for the shared facilities, with a saving of \$140 000 on the original estimate of

\$2.689 million.

The complex was opened in January 1996. Initial enrolments in 1996 were 169 students for Holy Spirit PS and 220 students for Nicholls PS. Both schools will require additional transportable buildings to accommodate their final enrolment capacities of 750 students at Nicholls PS and 670 students at Holy Spirit PS.

The joint facilities are administered by a management committee which includes the Director of the CEO, the chief executive of the ACT Department of Education and Training, and a chairperson appointed by the Minister. There is also a joint facilities management committee which includes the principals of Holy Spirit PS and Nicholls PS, three representatives from Catholic schools, three representatives from government schools.

The Committee examined the shared facilities concept in its public hearing with Mr Tony O'Donnell, Planning Officer for the CEO in the Archdiocese of Canberra and Goulburn.

Mr O'Donnell stated that the primary advantage of the shared facilities concept was the capacity to have all facilities available for use from the opening of the school rather than delivered in stages as enrolments warranted and funding allowed:

The facilities are quite magnificent for a primary school and the venture has worked in a positive manner.... We had up front in the way of facilities a hall, a gymnasium, a canteen and a big resource centre that possibly we would not have had in a school we were building over a period of time. (29-30)

Mr O'Donnell also indicated that the shared facilities concept enabled the size of individual facilities to be increased beyond normal limits:

Mrs BEAMER: I attend many schools where all the children do not fit into the hall so kindergarten and first class children do not attend school assemblies. Can you comment on that?

Mr O'DONNELL: It is normal practice for a hall not to hold a whole school of three streams or 670-odd children.

Mrs BEAMER: Have you built a hall that is big enough to house each of the schools individually?

Mr O'DONNELL: Yes, I think it would hold 700 seated people.

Mrs BEAMER: It is bigger than the one you would have envisaged for your school?

Mr O'DONNELL: We would never have built a hall that size.

Mrs BEAMER: Would the other school have done so?

Mr O'DONNELL: No, they would not have built a hall that size.

Mrs BEAMER: So you have a better facility that you both share?

Mr O'DONNELL: We have a much better facility and we also lease it out to the community at large. There is a smaller resource room that is being used as a

childminding after-school facility. (30)

In its opening statement to the Committee, Mr O'Donnell also touched on other educational benefits:

Educational advantages suggest obvious benefits to specialist curriculum areas with the capacity to share personnel or specialist teachers. The ability to combine specialist development activities is significant. Networking is possible to enable teachers to broaden their skills. The schools should be better resourced with access to combined funding with broader access to special needs programs such as reading recovery, resource remediation, languages and technology.

The ACT Government had subsequently proposed a high school joint venture:

Mrs BEAMER: Do you envisage that some high schools could be involved and share some of the hi-tech facilities?

Mr O'DONNELL: I will put it to you this way: the Australian Capital Territory Government approached us about sharing a high school at Nicholls. We have a block of land set aside at Nicholls for a high school, involving a joint venture between the Australian Capital Territory Government and the Catholic Church.... We would be happy to share some of the facilities, but we could not afford to build seven or eight laboratories. The Government has also said that it has planned the school so that we can add on and I have seen the plans. If we wanted to come in in five years time they would be happy for us to come in and share those facilities and we would pay proportionally at that rate. (34)

The Committee examined Mr O'Donnell about possible problem areas in the shared facilities concept.

The Committee put anecdotal evidence to Mr O'Donnell about disputes over timetabling the use of joint facilities in similar ventures in South Australia:

Mrs BEAMER: You talked about the disadvantages of the joint venture. One disadvantage put to the Committee is that a lot of time was spent between the schools timetabling the use of joint facilities. Have you found that to be a problem?

Mr O'DONNELL: I think that was put to us in Adelaide, but in the ACT we have not found that disadvantage. The two principals have not complained about that at all.

CHAIRMAN: When you say "was put to us", do you mean by the Catholic Education Office in Adelaide?

Mr O'DONNELL: That was from some of the principals at the schools. They put time into the proposal. I did not think there were real complaints.

CHAIRMAN: Did that question arise at a conference?

Mr O'DONNELL: The comment was made that it took time to work out the curriculum. In Adelaide there are four schools and in Canberra there are two. I do not think we have had any problems. Nothing has ever been said to me about the time. As far as I can make out, they seem to enjoy putting the time into it. (29)

Mr O'Donnell indicated that there had been additional initial running costs for the joint facilities. These costs had been offset by innovative financing strategies:

The recurrent costs of running the joint facility proved more expensive in its first year because of the small enrolment. However, it was possible to overcome some expenses through the public hiring of the facilities including the hall, canteen profits and excess funds from the child-minding facility. With the increase in student numbers, the cost per student will be more reasonable.

Mr O'Donnell stated that insurance was the single area of difficulty between the parties in the ACT:

Insurance is the only thing outstanding as far as the agreement goes at this stage. We have had trouble setting down insurance, so the Government has its own and we have insured ourselves for public liability, buildings, and so on.

The Committee was concerned about how the philosophical differences between a secular government school and a religious school had been handled.

In evidence before the Committee, Mr O'Donnell stated that there was a cooperative spirit between the schools which resulted in many joint activities:

The sharing of the facilities and the coming together of the two schools has worked smoothly. The campus has a policy of learning without boundaries or barriers.... Staff, students and parents are extremely cooperative. This is evident in the sharing of the canteen operation, joint choirs, joint sporting activities and joint parent social functions. There is also a close bond between staff in relation to professional development, ecumenical services and social events.

In addition, Mr O'Donnell argued his opening statement to the Committee that the shared facilities concept provided a model of working together for the benefit of the community:

Some of the advantages are quite intangible. How does one measure pastoral advantages such as breaking down barriers, shrinking gaps to promote better understanding and tolerance, developing a better system for the whole community that respects different traditions and the ecumenical division of society? The cooperation that arises from staff working together for community benefit provides a role model for children that is difficult to measure. The capacity in a new community to diminish any potential divisions that might be present and

enable the community to benefit from these resources is a major plus.

The Committee investigated the application of the shared facilities concept to NSW schools during its public hearing.

There are already examples of shared facilities in the NSW education system. The most recent example of this approach is at Southern Cross Community School (Ballina) which incorporates students from Kindergarten to Year 12 in an overall site master plan including primary, middle and senior schools. In addition to shared facilities between the schools, Ballina Shire Council has assisted community integration within Southern Cross Community School through provision of a public library and an extended gymnasium. The communal hall and gymnasium act as meeting places for formal occasions as well as performance spaces for drama, music, dance and sports.

The Committee inspected an example of this concept on a village scale at Terranora PS during its site inspection of schools on the NSW North Coast. A CDR hall with COLA had been constructed which was jointly funded by the local community so that it could be used as a general community hall.

The first experiments in sharing facilities between government and non-government schools in NSW have also commenced. In evidence, Mr Rowland of the DSE outlined progress at Quakers Hill:

Mr PRICE: Given that the experiment involving the Catholic education authority... appears to have been successful in the Australian Capital Territory, has the department explored a similar type of set-up for New South Wales—even if it is confined to specific areas, such as the sharing of playing fields, libraries, canteens, car parks and that sort of thing? Is there any capacity for the department to investigate that and perhaps act on it?

Mr ROWLAND: Yes, it has been explored, but to a lesser extent than in other States. We are currently building a senior high school at Quakers Hill that will share a library and a hall with a Catholic senior high school that is immediately adjacent to it. (13)

Mr Rowland stated that the concept of shared facilities had not been vigorously promoted in NSW because of procedural problems with involving non-government agencies in planning:

A few years ago we made some tentative representations to the Department of Planning, as it was then, to see whether the non-government school sector could be part of the planning process, as we are, in identifying school sites early in the development plan. There were difficulties because extending that right — if that is the correct word — to the non-government school sector had overflow effects into other service providers and non-government service providers, which seemed to be of concern. We have not been able to take a planned development, identify a piece of land and say, "On this site there will be a government school, on the site

next-door there will be a non-government school, and we can share some of the facilities".

Mr Rowland also suggested that there were legal impediments in NSW:

Mrs BEAMER: Could the Department of School Education do that with the Catholic schools and then go to the department?

Mr ROWLAND: My understanding is — perhaps the director of legal services or the Crown solicitor should advise the Committee — that the Minister does not have the power to identify the resources for the non-government sector.

Mr Rowland also argued that his examination of the concept in South Australia disclosed it could become an administrative burden:

Mrs BEAMER: Particularly in relation to green field sites such as ADI, it would appear that there could be great scope to do that with any non-government school provider, as the site is large enough for several primary schools.

Mr ROWLAND: I do not dismiss it as offering considerable opportunity. One caution is that our schools are designed for very high occupancy rates and we use them heavily — we do not have spare capacity in them for anyone else to use. If there is synergy, who gets access to what and whether additional resources are required has to be worked out carefully. My limited examination of this operation in South Australia indicates that a fair amount of school executive time goes into consultation and committee meetings just to keep it all organised — to keep the timetable happening, to keep playground interactions at a level everyone is comfortable with and to work out who has a responsibility for supervising which children if they mix in the playground. Those fundamental operational questions require a lot of time and effort on site to make them work. (14-5)

The Committee supports the concept of shared facilities between schools.

The DSE has successfully optimised the educational atmosphere at Southern Cross Community School in Ballina by consolidating an array of school and community resources. The DSE is also trialing the concept between government and non-government schools at Quakers Hill.

Clearly, the educational demands of primary schools lend themselves to this concept.

The Committee believes that the concept of shared facilities may also offer the possibility of considerable efficiencies in the delivery of expensive, specialised high school infrastructure.

Cooperation between government and non-government school planners is the key.

The Committee believes that the DSE should consider the development of shared facilities in NSW schools, especially in urban growth areas where there are longer planning lead times and an abundance of possible sites.

RECOMMENDATIONS

- 10. The Department of School Education consider the development of shared facilities in NSW schools, especially in Urban Development Plan growth areas where there is a longer planning lead time and access to suitable sites.**

CHAPTER 3

HIGH TECHNOLOGY LEARNING IN NSW SCHOOL FACILITIES

In this Chapter, the Committee looks at Term C of the Terms of Reference which requires it to report on whether school facilities in NSW are "of an appropriate standard to facilitate high technology learning."

Tremendous changes have occurred over the last two decades in the way students learn and teachers teach, and the impact of these changes on the NSW education system are profound. The contemporary school environment must allow for a diversity of teaching and learning modes.

The NSW Teachers Federation succinctly summarised this historic educational change in its submission to the Committee (s.5) when it stated that "the days of a chalkboard and one power point are gone from the annals of NSW public education."

Social and environmental changes in Australia over the past decade have made it imperative that the entire community (including students) become more innovative, knowledgeable, skilful, adaptable and enterprising. Technology plays a significant role in equipping students with the knowledge and skills to meet these challenges.

Evolving curricula in NSW schools have already dictated the need for audio visual equipment and computers which will facilitate access to the information super highway. Increasingly, schools are using a wide range of technological resources. The installation, use, secure storage and easy movement of high technology equipment will become an increasingly important factor in the design and construction of schools.

There are already detailed strategies directing the incorporation of high technology features into the NSW education system. These include the *Technology in Schools Strategy*, the *Computers in School Program* (including Internet access), and the Office Automation and School Information System (OASIS).

The Committee reviews these strategies and considers technology infrastructure requirements and related security issues in this chapter. It also investigates the future direction of high technology learning within NSW schools.

3.1 High Technology Learning

Over the past decade, the development of a variety of information technologies has changed how information is presented and delivered within educational contexts.

The use of information technologies in education provides students with greater opportunities including:

- Independent learning.
- Individually tailored learning.
- More active learning.
- Group work.
- Problem solving.
- Simulations.

Technology offers the potential to reconstruct and reconceptualise education. It provides the basis for rethinking how we deliver education programs, organise knowledge and structure the social relationship between teachers and students.

Applying technology to the school curriculum requires a combination of theory and practical experience. In the classroom, students need to learn how to understand information technology and then apply their learning to it. As the DSE/DPWS joint submission to the Committee (s.7) stated, “learning needs to take place *with* technology and *about* technology”.

The equal importance placed on theoretical and practical experience means that students need to have appropriate access to high technology equipment including computers, the Internet, computer networks and software packages. Through a process of designing, creating and appraising, students generate ideas and translate them into practice. They explore, apply and develop information, materials and systems. These processes are central to high technology learning.

The NSW Government is committed to the provision of computer resources, training and support to enhance education in NSW schools and to ensure that students benefit from the exciting possibilities presented by improved technology and global access to information.

In 1995, the NSW Government announced the *Technology in Schools Strategy* to ensure that teachers, students, and parents had sufficient knowledge and skills to use technology effectively. As part of this strategy, the NSW Government allocated \$177 million over four years to the *Computers in Schools Program*.

The aim of this program is to ensure that students have sufficient computer literacy and hardware to meet the challenges of the twenty-first century. In order to achieve this initiative, the DSE is required to concentrate departmental resources on a number of areas including:

- Provision of equitable access to computer resources.
- Making computer education integral to all key learning areas.
- Delivering relevant and substantial training and development for teachers.

This policy cannot be successfully executed by merely providing a large number of computers to schools. The joint DSE/DPWS submission to the Committee (s.7) noted that concepts of what constituted constructive access to technology were being refined:

The concept that proliferating stand alone personal computers and individual pieces of equipment lead to greater accessibility of technology by individuals is being replaced by the realisation that access to a range of equipment, including lap top personal computers, networks and specialist shared stations, allows for individual learning to occur and for limited resources to be more equitably distributed.

The implications of this policy are enormous for both existing and future school facilities.

In addition, technology has implications for administrative processes in schools. Advances in the field of electronic hard and software have affected administration and library operation.

The DSE has responded to these developments through the introduction of Office Automation and School Information System (OASIS).

OASIS software operates on personal computers in a single user or multi-user situation through a Local Area Network (LAN), allowing multiple simultaneous access to data in the system.

The LAN is controlled by the Novell Netware system with an interface card for network connection in each computer. The netware cable length limit is 300 metres including cables from wall outlets to computers.

Each school will have two networks (LAN): one for Administration and the other for the Library. They will not be interconnected to secure the OASIS Administration Network (OA LAN) from student access.

In the future, the OASIS Library Network (OL LAN) may be extended to general learning facilities or this may be done via another network.

The Committee acknowledges the efforts of the NSW Government to promote high technology learning through its *Technology in Schools Strategy* and *Computers in Schools Program*.

Already, Australia is one of the most computer-literate nations on earth with widespread personal and institutional access to personal computers and the Internet.

Current NSW Government policy will benefit students in NSW by placing them on the cutting edge of international technological developments in the future.

The Committee believes that equitable access to computer resources is the most important component of high technology learning in NSW school facilities.

In particular, the special needs of students in new urban growth areas and regional communities need to be recognised and given priority.

Urban growth areas often lag in the provision of services. The widespread use of demountables to cope with enrolment surges in new urban growth areas should not preclude access to high technology learning.

In addition, many regional communities are still suffering the social repercussions of protracted rural recession, adverse climatic conditions and the withdrawal of essential services.

Information technology and the Internet offer regional communities the opportunity to keep pace with a rapidly changing world.

The Committee believes that the DSE should review its policies with regard to high technology learning to ensure that both urban growth areas and regional communities are targeted as priority groups.

School facilities which are capable of incorporating information technology underlie these programs.

In the next section, the Committee investigates strategies being pursued by the DSE to update existing facilities to receive information technology and to develop facilities design so that future advances in technology can be easily and economically incorporated into NSW schools.

RECOMMENDATIONS

11. The Department of School Education review policies relating to high technology learning to ensure that urban growth areas and regional communities are targeted as priority groups for the provision of information technology infrastructure.

3.2 High Technology Learning and NSW School Facilities

The changing context of contemporary education has placed new demands on both the design and construction of school facilities.

The integration of technology into schools is best facilitated by designs which allow these services to be included as standard specifications. The construction of schools in the 1990s has overcome design problems associated with older school facilities by including ready connection to data networks, sufficient power supply and outlets, and appropriate levels of lighting and ventilation.

The submission to the Committee from James Hardie Building Systems (s.8) provided a checklist of design features needed to meet the requirements of emerging technologies:

- Additional visual access to facilitate supervision.
- Access for cabling, separate ducts for data, voice and power cables.
- 3 phase and single phase power circuits; Vacuum, compressed air, gas lines.
- Sturdy construction to accommodate various types of equipment including high point loads and vibration impact.
- Access and easy loading for large items.
- Appropriate controls for ventilation, air conditioning, lighting and dust.
- Appropriate fittings and fixtures.
- Secure space with access control for expensive equipment.
- Maintenance areas for hi-tech equipment.
- Safety systems for equipment.
- Fire-safety equipment, alarms and lighting.

In recent years, the DSE has committed itself to providing access to information technology for all students by incorporating these kind of features into existing school facilities and facilities designs.

Recent NSW Government policy initiatives have placed increased pressure on the DSE to upgrade technology services. Most commonly, this has required extensive cabling networks in schools to enable access to computer 'networks' and the Internet.

In evidence before the Committee, Mr Rowland of the DSE outlined the problems with the introduction of information technology into NSW school facilities:

There are significant problems with the current introduction of technology. From my perspective the two greatest are the increased demand for security - a simple problem but a difficult and expensive problem when one goes right across the system - and the increased demand for wiring and cabling, both for power supply and networking facilities within the school. It is quite expensive to retrofit old buildings, particularly large complexes of old buildings, such as high schools, with the current systems of computer cabling and perhaps, if necessary, update the power supply. The capital costs of such a retrofit in an older high school are in the order of several hundred thousand dollars, and there are several hundred high schools. Significant capital investment is required to make the buildings ideal for the introduction of new technology. New technology can be introduced and it will have significant benefits, but it may require something greater to get ideal performance from it. We are gradually working on that problem, but it will not be resolved in one budget. (7)

Mr Rowland identified two areas of concern for the DSE with regard to information technology: providing adequate security for expensive information technology equipment and retrofitting existing facilities so that they can use this technology.

As a result of Mr Rowland's evidence, the Committee placed a series of Questions on Notice to

the DSE concerning the incorporation of information technology equipment into school facilities standards. The DSE reply on 9 April 1997 stated:

Both primary and secondary school facilities standards (ie. building code for new and refurbished schools) provide for ready access to voice, video, and data communications. It is now agreed that for technology to be broadly accessible it must be available in all teaching and learning environments. The experience of locking up expensive computer equipment in a computer room is now being overtaken by flexible use of computers as a tool across all Key Learning Areas.

In both primary and secondary schools the communications provision is now centralised around the library audio-visual facility. The backbone cabling around the school can consist of optic fibre, Category 3 or 5 UTP cable depending on the design solution provided by consultants under State Contract 2012.

Each primary homebase is serviced with four communications outlets which may be configured to receive voice/video/data, the normal configuration being one video and three data outlets. Primary learning spaces, unlike secondary, are the focus for all Key Learning Area experiences and with existing provision should be able to cater for technology in the immediate future.

The Committee was also concerned with the ability of NSW school facilities to meet future demands for technology.

The Committee placed a Question on Notice with the DSE concerning the flexibility of current school designs. The DSE replied:

The Education Facilities Research Group is in regular contact with service providers and DSE Technology Directorate to identify issues which will affect the communications provision.

The future provision of such technologies as multimedia and virtual reality in the learning environment will require large bandwidth communications. To provide this, Category 5 UTP (untwisted pair) communications cabling is being provided in all new schools and upgraded facilities with a rating of 100MB/s. This will hopefully “future proof” schools to changes in technology for the next five to ten years.

Clearly, the DSE and DPWS - through the Education Facilities Research group - are ensuring that NSW school facilities can accept advances in information technology by incorporating design features which allow ready connection to networks and power and appropriate levels of lighting and ventilation.

3.2.1 Upgrading Existing Facilities

The conversion of existing facilities so that they can utilise information technology is often more expensive and time-consuming than refining designs for new facilities.

The joint submission from the DSE/DPWS (s.7) noted that “existing permanent facilities vary

enormously in their provision of services for technology". These variations are due to differences in age, design and construction techniques. The need to integrate new technologies into NSW schools was not a priority until the late 1960's when the design of schools became more adaptable and flexible. Previously, schools were designed to meet the basic needs of students and teachers.

Difficulties encountered when upgrading existing facilities stem from the inflexible building designs of the past. The construction of school facilities has traditionally been of brick. This has made it physically difficult (and expensive) for the DSE to gain access to existing wiring and cabling, and has led to problems in the integration of services required for the introduction of technology links.

The primary services required for the incorporation of information technology into school facilities are:

- increased power supply.
- increased number of power outlets.
- increased cable size to support computer networks and the Internet.
- increased number of data outlets.

The Committee believes that the DSE should undertake a review of existing NSW school facilities to determine their capacity to receive information technology equipment.

This review should concentrate on the ability of school facilities to meet both current technology and emerging technologies.

The anticipated cost of updating school facilities to appropriate levels of technological capacity should also be outlined.

RECOMMENDATIONS

- 12. The Department of School Education undertake a review of the technological capacity of existing facilities in the NSW education system.**

This review should focus on the ability of existing facilities to meet current and future technology requirements, and the cost of updating these facilities to the appropriate level to enable access to information technology.

3.2.2 CDR and Kit Facilities Design

The relatively recent development of CDR and Kit lightweights within the NSW school system has meant that access for emerging technologies can be easily incorporated into the design phase.

However, research undertaken by the Committee has suggested that the placement of cables and wiring may detract from the flexibility of school facilities if not planned carefully. Retaining design

flexibility is essential for modern teaching practices.

The flexible design of lightweight permanent buildings has encouraged the use of high technology to date. As the submission from the NSW Teachers Federation (s.5) stated:

Often times, the withdrawal area was used as a computer room between two or more classrooms, which allowed for high technology use of a small space. Teachers also remarked upon the ease of access for energy conduits.

One shortcoming was identified by the NSW Teachers Federation:

The only problem noted was the location of TV/computer point directly under the chalkboard in a number of classroom modules. This design fault is one that needs to be rectified in future construction.

The Committee believes that the Post-Occupancy Evaluation of new and upgraded facilities should ensure that minor problems - such as the location of power and cable outlets - are brought to the attention of the Schools Building Research and Development Group (SBRDG).

There are also potential problems from the proliferation of cables in existing classrooms as new technology comes online.

The Committee inquired into the accessibility of electrical wiring and information cables in existing CDR and Kit lightweights. In evidence, Mr Zahn of the DPWS suggested an innovative solution to the increasing number of cables required by classrooms:

We are looking at cable trays in standard schools. Even though those in the new schools are very lightweight, as members would well know it costs money every time an electrician is asked to come into a home to move a power point and put an AV point in. We are looking at putting in a system of a cable tray with electrical wires which would sit above a window with the pelmet in front of it, so if they wanted to hook up a computer or another power point this could be done.
(46)

An easily-accessible cable tray would enable lightweight facilities to easily accommodate the future installation requirements of high technology learning.

The Committee was also concerned about the capacity of lightweight libraries to cope with technological advances.

The primary school library is a focal point of educational activities, resources and services.

For example, the OASIS library network (OL LAN) discussed in the previous section is based in the library to provide research access for both teachers and student. The library also contains the

Audio Visual Workroom, which serves as a work space where staff members and small groups (2 - 5 students) can work with recording and film equipment. This space also serves as a room for secure storage of expensive A/V equipment.

The NSW Teachers Federation supported the use of lightweight buildings as libraries (s.5):

The Internet connection has been installed in a small number of lightweight construction library buildings. These buildings often replaced what had been existing demountable library buildings. In one school, the satellite dish was also installed on the library roof making the library a true technological resource centre.

The Committee agrees that the use of cable trays would make the integration of high technology equipment within the classroom easier.

RECOMMENDATIONS

- 13. The Department of School Education equip all new NSW classrooms with cable trays to enable cost effective access to high technology equipment. The installation of cable trays should also be part of the refurbishment of existing facilities.**
- 14. The Department of School Education and the Department of Public Works and Services review the Component Design Range to ensure that TV/computer points are not located directly under chalkboards in classroom modules.**

3.2.3 Demountables

The design of demountable buildings originates from the 1960s - before technology became an integral component of the education system. Due to the age of the DSE's demountable stock, the majority of these buildings do not make any provision for access to technology infrastructure.

The DSE/DPWS submission (s.7) noted that it was possible to provide demountable buildings with access to information technology:

Demountable buildings can be fairly readily serviced, at a cost, to allow technology links to be effected with the rest of the school. Broadly, demountable technology access depends upon the availability of equipment and expertise in the delivery of educational services as it is upon the built environment.

The NSW Primary Principals' Association submission (s.6) advocated introducing the power and space to accommodate computers in all classrooms.

However, the Association noted that the ability to incorporate technology (especially computers)

into demountables was severely limited in the following respects:

- Many demountables do not have a power supply adequate to support computers.
- The number of power points in demountables is insufficient to support computers.
- The location of power outlets in demountables is not appropriate for the effective positioning of computers.

The submission from the NSW Secondary Principals' Council (s.9) was in accordance with that of the NSW Primary Principals' Association:

High technology learning is always going to be difficult in demountables. Co-axial cabling is not included in installation. We believe it should be. Technology education and education using technology is not a matter for specialist rooms. All rooms are technology learning spaces. Demountable classrooms all need cable tracks and should all be connected to electronic security.

The call to upgrade demountables to the same level of capacity as other school facilities also raises the vexed question of security.

The submission from the NSW Secondary Principals' Council (s.9) noted that schools were reluctant to store equipment in demountable buildings because of lax security:

Schools are reluctant to use and store expensive technology in demountable classrooms which are often not connected to electronic security and appear not to be as secure. The hopper windows used in many demountables are not as secure as windows with locks.

In its submission to the Committee (s.5), the NSW Teachers Federation chronicled one instance in which thoughtless efforts to improve the security of demountables had resulted in the degradation of the student learning environment:

Teachers continually note the discomfort of their students in demountables especially through the summer months. One particular new school, in the Windsor area, gave an example of the inadequacy of the design of demountable buildings on site. Because of instances of vandalism, windows had been pop rivetted shut, hence no air could circulate except with the door open.

For demountables to be secured for high technology equipment, security needs to be upgraded to the same level of stringency as permanent lightweight buildings.

The Technical Specifications (section 31) of the Primary School Facilities Standard developed by the Schools Building Research and Development Group stated that security measures should include:

- **Windows:** Securable
Physically protected (eg. internal or external grilles)
- **Doors:** Lockable, blockboard core door leaf, with 2-point deadlocking.
Steel door frame.
Roller shutters to be steel (50 mm slats).
- **Roofs:** Ensure roof penetrations (ie. daylight strips) are protected.
- **Electronic:** Where possible demountable buildings should also be linked to the schools' security alarm system.

The Committee believes that it would be economically irresponsible to advocate the upgrading of current demountable classrooms to the standard of high technology learning spaces.

The cost of installing technology access and additional security into current demountables is too high.

Obviously, any new relocatable buildings designed or purchased by the DSE should consider technology access as a priority. This would mean the incorporation of such items as cable trays, AV outlets and co-axial cabling as well as adequate security.

CHAPTER 4

THE ENVIRONMENTAL SUSTAINABILITY OF NSW SCHOOL FACILITIES

In this chapter, the Committee looks at that part of its Terms of Reference which requires it to report on “environmental sustainability especially energy management” in NSW school facilities.

The Committee interpreted this Terms of Reference to mean that it should report on:

- DSE/DPWS policies to implement the principles of Ecologically Sustainable Development (ESD) including associated environmental policies.
- The current environmental impact of school facilities.
- Innovative environmental design features which may have a significant impact on school facilities in the future, particularly in relation to energy management.

The Committee was aware that its Terms of Reference confined its assessment to some extent. It has retained its focus on the relative environmental costs and benefits of lightweight and demountable school buildings. However, the overarching environment policies of the DSE and the DPWS must be considered in such an examination.

The Committee opens this chapter with an outline of the history and content of ESD principles.

4.1 The Concept of Ecologically Sustainable Development (ESD)

The concept of ESD arises from a belief that the current systems of resource allocation fail to account adequately for:

- Interactions between the economy and the environment, and the impact of the environment on people’s quality of life.
- The consequences of people’s current use of the natural environment for the future generations.¹

In 1992, the National Strategy for Ecologically Sustainable Development (NSESD) was endorsed in Australia. The NSESD defined ESD as:

Development that uses, conserves and enhances the community’s resources so that ecological processes, on which life depends, are maintained and the total quality of life, now and in the future, can be increased.

¹ Wills I, "The Ecologically Sustainable Development Process: An Interim Assessment" in *Policy*, Spring 1992.

The guiding principles and objectives for the NSESD were designed to:

- Enhance individual and community well-being and welfare by following a path of economic development that safeguards the welfare of future generations.
- Provide for equity within and between generations.
- Protect biological diversity and maintaining essential ecological processes and life-support systems.

It was also realised that single measures of sustainability will not lead to any substantial change in design or construction techniques. Therefore, ESD should be seen as a conceptual framework against which design and construction techniques are assessed, rather than a precise standard.

The DSE and the DPWS have attempted to enshrine these ESD principles in the design and construction of NSW school facilities.

In the next section, the Committee outlines the relative responsibilities of each department in the ESD implementation process before going on to assess the policies which have been developed to advance this cause.

4.2 The ESD Policy of the DPWS

The Working Agreement between the DSE and DPWS outlines the respective roles that each department plays in the development of school facilities.

The DPWS is responsible for the design and project management of school facilities. Therefore, the construction of school facilities adheres to the ESD policies implemented by the DPWS.

The ESD policy of the DPWS charges the department, its consultants, contractors and suppliers to achieve a balance between environmental, social and economic objectives by:

- The preservation, maintenance and sustainable use of the community's natural and material assets.
- A decision-making process which considers both short and long term economic, environmental, social and equity imperatives.
- Ensuring that environmental impacts are properly identified, assessed and valued and included in cost benefit analysis of projects and purchasing activities.
- The continued development of environmental protection and enhancement measures in all projects and purchases.
- Effective and appropriate community consultation.
- Protecting and supporting biological and ecological diversity.
- Minimising or avoiding the discharge of pollutants.
- Considering local, regional, national and global dimensions of the environmental effects of its actions and policies.

The DPWS has implemented a number of integrated policies within the ESD concept frame to reduce non-renewable resource use and wastage in the construction and operation of schools across NSW. These policies include the use of environmentally friendly materials and products, conservation of biological diversity, and waste management for project management, design and construction.

The Committee outlines these DPWS policies in the following sub-sections after examining the overarching Environment Policy of the department.

4.2.1 DPWS Environment Policy

The DPWS Environment Policy was introduced in August 1996 to meet the NSW Government's general environmental priorities by promoting ESD and facilitating improved environmental outcomes in the design and delivery of capital works and services.

The DPWS Environment Policy:

- Identifies and sets specific targets for improved environmental performance in energy efficiency, water conservation, water minimisation, pollution reduction and public safety. It is expected that construction waste will be reduced by 30% by 1997 and public sector facility energy consumption will be reduced by 10% by 1999. An environmental product profiling system has also been implemented and environmental plans will be adopted in all DPWS construction contracts.
- Develops policy programs that focus on the delivery of tangible progress towards - and a more general understanding of - ESD principles. These programs include standards of practice to minimise adverse environmental impacts and achieve measurable improvements in resource conservation and protection of biological diversity.
- Works with clients and the community to identify and develop capital and maintenance projects with improved design, construction and management practices. Goods and services purchasing procedures that encompass environmental objectives are also encouraged.
- Works with industry to develop agreements which ensure achievable waste avoidance, resource conservation and recycling targets are established. The use of environmentally friendly products and services is supported where it provides a cost effective option.
- Ensures that all employees and contracted suppliers of goods and services are aware of their environmental responsibilities and obligations in relation to DPWS activities.
- Establishes specific environmental management, reporting and auditing mechanisms to demonstrate to government the Department's environmental performance and to measure and facilitate continuous improvement in best practice environment management.

4.2.2 Environmentally Friendly Materials and Products Policy

An important part of the DPWS Environment Policy is the Environmentally Friendly Materials/Products Policy. This policy aims to ensure that materials, products and processes with significant detrimental environmental impacts are not used in the construction of school facilities.

To achieve this objective, the DPWS encourages the use of materials and products which adequately and economically perform their intended functions while having lower adverse environmental impacts throughout their life cycle. In short, products which are manufactured with lower pollution and waste emissions while using less energy.

The environmental impacts of commercially available materials and products are assessed to identify viable alternatives to current products and materials.

Tender evaluation procedures include environmental performance criteria. Contracts for the procurement of materials and products include clear reference to desired environmental performance.

Concurrently, the DPWS discourages - or where possible eliminates - the use of buildings products and materials which are known (or reasonably suspected) to be detrimental to human health and the environment.

The DPWS also discourages the use of raw materials or resources which are endangered, rare or require preservation.

Finally, the DPWS encourages the selection and use of materials and products that contain - or are manufactured with - recycled material, where it can be demonstrated they are quality, cost and value competitive and offer the lowest life cycle environmental impact.

4.2.3 Conservation of Biological Diversity

Consideration of biological diversity (all variety of life forms) and ecological processes (the systems that support these life forms) is the foundation of ESD.

The NSW Government specifically adopted this policy in its 1996 endorsement of the National Strategy for the Conservation of Australia's Biological Diversity. The NSW Government is committed to protection of the natural environment and management of the built environment.

The DPWS Environment Policy includes a strategy for the conservation of biological diversity.

This strategy requires the DPWS to protect the natural environment and conserve the biological diversity of genetic materials, species and ecosystems in NSW.

Protection of the natural environment involves three simple objectives: save it, understand it, and use it sustainably.

Unfortunately, it is more difficult to gain a clear understanding of complex ecological relationships and the management of ecosystems and habitats. Such relationships extend beyond the boundaries of any particular site and must be identified in the course of specific site development, maintenance and operation of existing facilities, and planning for purchasing contracts.

The DPWS is obliged to ensure that:

- Biological diversity is conserved on an ecosystem management basis as well as on a species and genetic basis. This requires wherever possible and practical:
 - the conservation of viable site populations of all native species and their habitats;
 - ensuring that the evolutionary and ecological processes and habitats on sites are maintained; and
 - site replanting and remediation activities.
- The impact on the environment of project and purchasing policies - including cumulative impacts - is thoroughly assessed during planning, design and contract establishment phases.
- Appropriate advice is made available to clients and stakeholders to allow informed decisions which address environmental impacts and where appropriate remediate natural environments and restore damaged habitat.
- The expertise of other agencies and organisations skilled in ecosystem management techniques and biodiversity conservation is obtained and applied where and when required.

4.2.4 Waste Management

The DPWS Environment Policy includes strategies on waste management.

Two key objectives of ESD are to eliminate unnecessary waste and to inhibit the flow of pollutants into the natural environment. These goals are achieved by better planning, the more efficient use of natural and manufactured resources, and recycling and re-use strategies.

The best answer to waste is not to produce it in the first place. This remains a good basic test when assessing Waste Management performance.

Of all project tasks, good design and project management are the most influential aspects in avoiding unnecessary waste.

To assist in recycling and reducing waste, DPWS requires project managers and designers to:

- Evaluate the project design for better functionality and material use or opportunities to make less waste.
- Give consideration to - and adopt in design where practical - the use of recycled materials where they meet design, performance, cost/value and workability criteria.
- Give consideration during the design phase to recycling project materials and components.
- Consult with client representatives to incorporate facilities for waste management programs.

The DPWS requires construction contractors to reduce waste on sites through the preparation and implementation of Waste Management Project Plans. These plans indicate the actions that

contractors will take to reduce waste and recycle/re-use viable waste materials from the construction process.

During the tender period, contractors are required to prepare a Waste Management Project Plan and to include the costs of implementing this plan as part of the tender price. The successful tenderer is required to fully implement the plan, manage waste collection, monitor material volumes and record methods of disposal.

The Waste Management Project Plan must provide for surplus soil, excavated rock and demolition materials to be recycled rather than contribute to landfill volumes. This is in line with the NSW Government's current policy to reduce landfill volumes by 60 per cent.

Provision must also be made to separately collect and stream quantities of waste concrete, bricks, blocks, timber, metals, plasterboard, paper and packaging, glass and plastics and offer them for recycling or re-use.

The Committee believes that the ESD policies implemented by the DPWS have the potential to make significant gains. These policies address all aspects of design and construction which have the potential to impact on the surrounding environment.

4.3 The Environmental Impact of School Facilities

In this section, the Committee deals with the environmental impact of permanent and demountable lightweight school buildings.

In line with the Working Agreement between the departments, the DPWS and the DSE have combined resources to ensure that the design of new school facilities - such as the CDR - incorporates ESD strategies for energy management and water conservation.

Unfortunately, the capacity of the DSE and the DPWS to improve the environmental sustainability of school facilities is limited by the unsympathetic design of most existing buildings, which were constructed before the emergence of concepts such as energy management.

For example, traditional school buildings are often lacking in light and thermal comfort. A past solution to these problems was to simply strengthen the wattage or number of lights and install gas heaters. This dramatically increased the energy consumption of NSW schools and, with it, the ongoing cost of maintaining them.

By contrast, the DSE and DPWS have recently commenced a program for the design, implementation and assessment of passive energy innovations in schools.

The incorporation of energy management systems has become an integral component of NSW school facilities design. The joint submission from DSE and DPWS (s.7) defined energy management as:

... the management of systems to reduce the use and cost of energy, incorporating the adoption of the most efficient and effective energy source to satisfy environmental strategies such as the reduction in greenhouse gases.

This program has already resulted in significant reductions (both economic and environmental) in the costs of electric lighting, gas heating and air conditioning.

The collective efforts of both departments to meet environmental objectives is embodied in the work of the Schools Building Research and Development Group (SBRDG), a joint thinktank of the DSE and the DPWS, which develops and tests environmental innovations.

The SBRDG has concentrated on developing energy saving mechanisms which can be implemented into new and existing school facilities at reasonable cost. The goal is to maintain comfort levels while incorporating low energy ideas and environment principles.

4.3.1 CDR and Kit Facilities

Both CDR and Kit school buildings are at the forefront of technical innovations concerning the adoption of passive environmental design principles to address issues of ventilation, insulation, lighting and orientation.

Passive energy mechanisms utilised in lighting for CDR and Kit buildings include:

- *Daylight Strips.*
Two daylight strips run the width of the homebase to give a workable level of natural light. This reduces school dependency on electric lighting. As the strips allow heat to enter the room, the width needs to be limited to 200 mm to maintain comfortable learning conditions and avoid glare.
- *Lighting controls.*
These controls automatically switch off lights when rooms are either unoccupied or natural lighting levels are sufficient for work. Extensive trials in primary schools have resulted in a period bell system being introduced, which is linked to lighting controls that turn off lights. Using these controls, home base lights are switched off 2-3 minutes after the bell is sounded. This saves electrical consumption when the room is unoccupied during recess, lunch and after school.
- *Low energy security lighting.*
All homebases are fitted with low pressure sodium vapour lamps (SOX lights) to augment normal lighting outside school hours. SOX lamps consume 5 percent of the energy used for normal lighting in homebases.

Ventilation is enhanced by the following strategies:

- *Roof (turbo) ventilation.*
Roof spaces are generally insulated to reduce the amount of heat in summer and to limit heat loss in winter. Ventilation of the space between the roof and ceiling further limits heat transmission to the classroom. In CDR buildings, air circulation in the roof space is achieved by ensuring the easy flow of air from the eaves through the airspace gap between the ceiling and the insulating material. Perforated purlins assist air flow and the heated air is exhausted by the turbo ventilators.
- *Cross ventilation.*
Natural ventilation is preferred in schools, although mechanical ventilation and evaporative cooling systems are used to improve comfort conditions in areas with very harsh climatic conditions. The homebase is designed for excellent cross ventilation with windows situated on opposite walls and protected from sunlight by single loaded covered walkways and expanded window eaves. Roof ventilators mounted on the ridge of the roof extract heated air from the room as well as the roof space. In winter, the roof ventilators can be switched to minimal ventilation.

Heating and cooling costs are reduced by:

- *Cost effective heating.*
Generally, gas heating is the most effective life-cost heating for schools. This is based on the costs associated with the equipment and the total energy consumed over a number of years. In temperate areas of NSW where heating requirements are low, radiant electric heaters are used. Timers are installed on all heaters. Gas heaters have an in-built three hour timer and a electric heaters have a two hour timer.
- *Orientation of school buildings.*
The cost of heating and cooling classrooms can be effectively reduced in the design stage by orientations which maximise winter sun and minimise exposure in summer. The preferred orientation for school buildings is northeast.
- *Flexible roof options.*
By incorporating flexible roof options into the design of CDRs and Lightweight Kits, facilities can be designed to suit the environmental conditions of the site and to maximise energy conservation.

In evidence before the Committee, Mr Zahn of the DPWS summarised the impact of these energy management features, using the recently constructed CDR school at Bligh Park as an example:

Another instance is the Bligh Park Public School. We had roof strips that were the full width of an acrylic sheet and the heat load in the rooms was gigantic. It is only 190 millimetres and there are two in each classroom. That is all there is and the

amount of light is unbelievable. The research group has a sealed diffuser underneath the light strip. It is a sealed unit like that under a fluorescent tube, a perspex area, and they run up in the same line as the turbo ventilators. With the system we have in place now we are ventilating the roof space because the purlins are built in a special way that dramatically reduces the temperature coming into the classroom and they are ventilating the classroom space as well. The ventilators on the roof are controllable. In winter the teacher should turn them off to keep the heat in the room; in summer they should be opened right up. It fits in perfectly with the Government's thinking about the environment. It is fantastic. (53)

Mr Zahn disclosed to the Committee that recent studies undertaken by the SBRDG had measured dramatic cost savings through energy management strategies such as lighting strips in new school facilities:

The research group has found, and I actually have some studies on it, that the CDR with the light strips results in more than a 15 per cent energy saving in each new school, compared to a 1989 school. The classroom must be giving us something like 25 per cent saving on electricity because there is no need to turn the lights on. That is the result of the roof strips in each classroom. Even in winter the lighting level is fantastic. Really, if the teacher turns on the lights it is foolish because you would not know the lights were on in a lot of places. That has taken a lot of work. (53)

In addition to energy management strategies, water conservation in schools is also seen as an important element in achieving ecologically sustainable development. Water is a precious resource in Australia and considerable recurrent savings can be achieved by the implementation of water conservation strategies.

These strategies include the specification of:

- Internal flow controllers to all taps to reduce water flow.
- Fitting of dual flushing cisterns in all toilets.
- The inclusion, where appropriate, of detention basins on site with the purposes of reducing storm water flow.
- Dams, where appropriate, to collect site water for irrigation of school grounds.

The Committee questioned Mr Zahn during its public hearing about the impact of water conservation strategies. Mr Zahn provided an example of the dramatic reductions in water usage which can be achieved by fitting water conservation infrastructure into schools:

We are doing water management studies. Weston School has decreased the size of water pipes to water meters and has spring-loaded taps and a few other things. The school has achieved massive savings in water and, taken across the State, this is a small capital cost for a massive return. It pays itself off in 1.2 years. (51)

Finally, the Committee heard that construction materials in CDR schools were constantly being monitored and updated in accordance with ESD principles. Mr Zahn provided examples of current innovations being investigated by the SBRDG including school facilities for use in the urban development area around the Sydney 2000 Olympics site:

A CDR school under construction by Donnelly Constructions near Camden is probably the cutting edge of environmental design. It has something that I did not know existed, paint that does not give off any fumes.... There are a few other problems, too, with PVC and things such as that. We are finding out how much it would cost to install a lot of these environmental features. The Olympic School, which we are now starting to plan, will have all these features plus a few others. We are trying to minimise the amount of paint used in schools, and trying to put the paint at a higher level so it will last a lot longer. (54)

The Committee recognises that the incorporation of energy management and water conservation design features into school facilities by the DSE and the DPWS has been an environmental and economic success.

Clearly, the initial outlay on these features is quickly recouped and a lasting environmental and economic benefit achieved.

The Committee commends the DSE and the DPWS for diligent implementation of ESD principles in new school facilities.

4.3.2 Demountable Buildings

The design and construction of demountable buildings is inefficient and therefore they are uneconomical in their use of energy. This scenario is hardly surprising given the era in which they were constructed, their current age and the limited funding for refurbishment of demountable accommodation.

A survey conducted by the NSW Teachers Federation and included in its submission to the Committee (s.5) found that demountable building design contained a poor system of energy management. The submission noted that demountables could not cope efficiently nor effectively with either heat or cold.

Thermal comfort is being addressed in the current demountable refurbishment program. However, the DSE and the DPWS concede that there is a serious problem with providing thermal comfort in temperature extremes. The DSE/DPWS submission (s.7) stated that, "it is undeniable that thermal comfort conditions in demountable buildings are not optimum."

The thermal deficiencies inherent in demountables are so problematic that the DSE has initiated a program to provide air conditioning. This policy is contrary to the ESD policy followed by DSE/DPWS and will increase energy usage and greenhouse gases. In addition the capital cost of air conditioning for a four module demountable is around \$10,000 for a unit with a 10-15 year

life span. However, the Committee recommended at 2.4 of this Report that such a policy was necessary to make demountables viable learning spaces in areas of NSW subject to climatic extremes.

Options which rely less on heavy energy use and are compatible with current ecologically sustainable design are being explored by the DSE. It is likely that thermal comfort in demountables will be enhanced markedly through redesigning existing roofs and improving insulation.

The DSE has shown that it is possible to improve comfort conditions - particularly thermal comfort - by implementing passive energy strategies. These include:

- Northeast orientation of demountables to gain warm winter sun and keep out heat during summer.
- Landscaping to provide shade and therefore some natural cooling.
- Incorporating a “Fly Roof” into design to improve ventilation and thus air flow through the interior of the demountable.
- Improving interior insulation to reduce the temperature extremes often experienced within demountables.
- Installing larger windows to improve cross ventilation.
- Window eave protection to reduce direct sunlight and enable windows to remain open during wet weather, improving cross ventilation.

The Committee has already addressed problems with demountable buildings in Chapter 2 of this Report.

At 2.3.5, the Committee recommended refinements to the demountable refurbishment program which would correct their poor performance to some extent, including the incorporation of various ESD features.

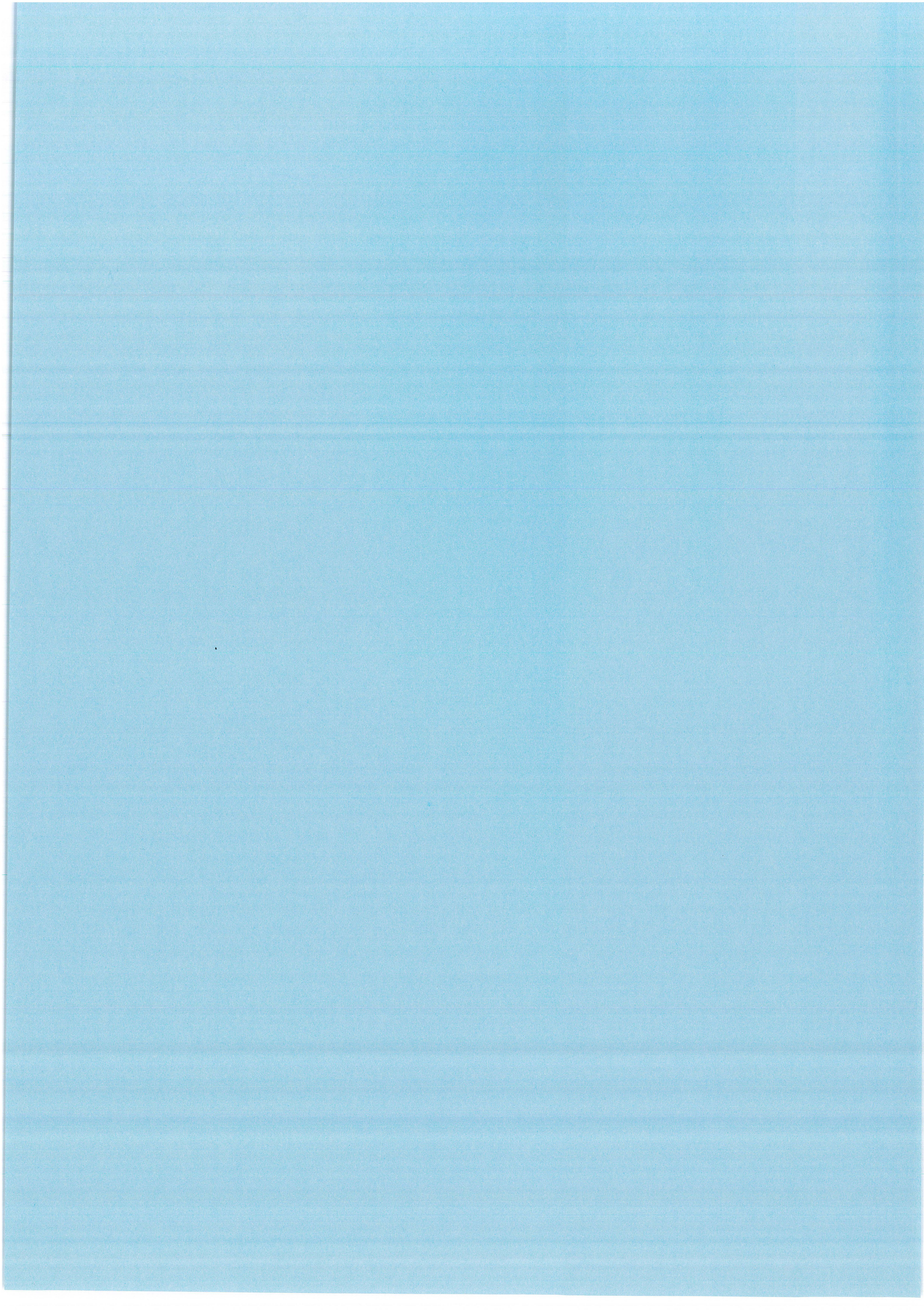

APPENDICES

Appendix 1: DSE and DPWS - Respective Accountabilities for School Facilities

Appendix 2: School Populations - Far North Coast 1977 - 1996

Appendix 3: The Core Plus System - A Guide

Appendix 4: Project Timeline - Barnsley Public School

Appendix 5: Component Design Range - A Guide

ACTIVITIES AND PROCESSES RELATING TO ASSET LIFE CYCLE

ACTIVITIES		ACCOUNTABILITIES				*DSE: PWS
		Asset Acquisition	Asset Maintenance	Asset Renewal	Asset Disposal	
A.	Strategic Planning & Development	ddddd p	dd pp	ddd p	ddddd pp	90:10
B.	Research & Standards	ddddd ppp	ddddd pppp	ddddd ppp	ddd pp	60:40
C.	Development of Annual Capital/Recurrent Programs	ddd pp	ddd p	ddd p	ddd p	90:10
D.	Community Consultation	dddd ppp	dddd pp	dddd pp	ddddd pp	70:30
E.	Project Brief	dddd pppp	dd pp	ddd ppp	dd pp	50:50
F.	Financial Management	dddd pppp	ddd ppp	ddd ppp	dddd p	50:50
G.	Risk Management	dddd pppp	ddd ppp	dddd pppp	dddd pp	50:50
H.	Project/Program Mangement and Monitoring	ddd ppppp	ddd ppppp	ddd pppp	ddd pp	30:70
I.	Design	d pppp	d p	d pppp	d p	10:90
J.	Contract Documentation, Tendering & Administration of Contracts	d ppppp	d ppppp	d ppppp	ddd ppp	10:90

KEY: d...dddd Low to High input from DSE
p...ppppp Low to High input from DPWS

NOTE: * These ratios are only provided as an input to the Asset Portfolio Accountabilities Diagram

ASSET PORTFOLIO

Accountabilities

DSE

DPWS

STRATEGIC

Strategic Planning & Development

Research & Standards

Development of Annual Capital/ Recurrent Programs

Community Consultation

Project Brief

TACTICAL

Financial Management

Procurement & Risk Management

Project/Program Management & Monitoring

Design

Contract Documentation, Tendering & Administration

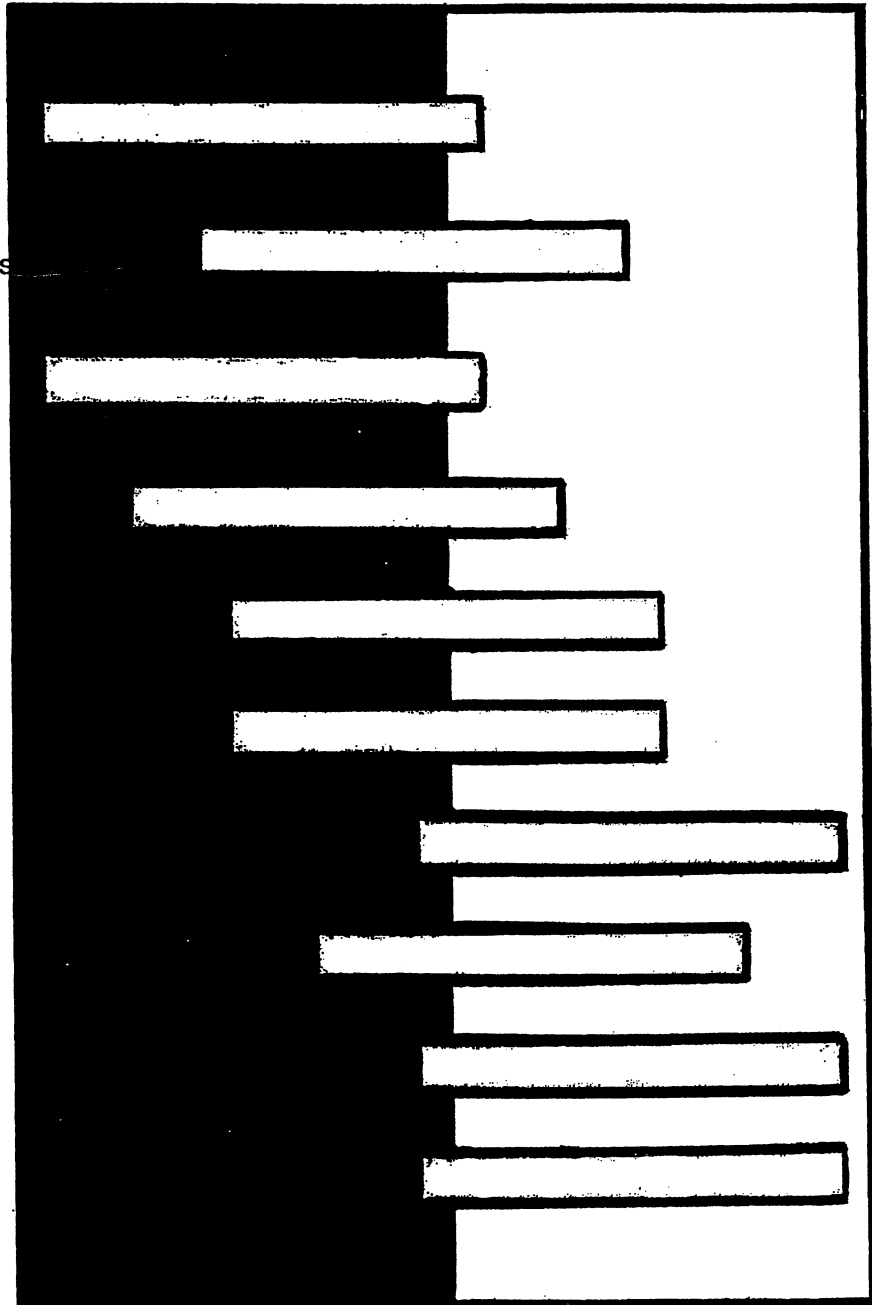

CODE	NAME	LEVEL	TOT77	TOT78	TOT79	TOT80	TOT81	TOT82	TOT83	TOT84	TOT85	TOT86	TOT87	TOT88	TOT89	TOT90	TOT91	TOT92	TOT93	TOT94	TOT95	TOT96
5172	Murwillumbah South Inf	I	39	39	37	37	38	43	46	47	42	34	43	37	40	35	39	46	49	58	51	61
1129	Banora Point	P	186	201	237	237	274	294	325	312	318	338	308	344	379	381	391	406	436	426	417	448
1224	Bilambil	P	12	16	15	17	26	54	80	97	98	103	123	143	189	205	228	263	285	293	316	331
1449	Burringbar	P	84	90	85	97	97	104	103	102	119	127	147	151	141	158	187	189	185	248	161	162
1515	Carool	P	21	26	24	29	31	32	33	40	42	42	40	49	48	43	29	10	15	13	14	20
4607	Centaur	P	0	0	0	0	0	0	0	0	0	0	0	0	0	0	0	0	0	0	293	380
1558	Chillingham	P	54	55	51	56	69	64	73	68	59	62	61	58	72	59	57	59	57	57	57	63
1611	Condong	P	52	53	63	62	74	80	85	96	92	90	99	114	101	101	90	90	92	85	85	89
1674	Crabbes Creek	P	24	22	23	31	36	35	36	34	33	29	35	37	41	46	55	59	57	69	57	53
1690	Crystal Creek	P	28	28	32	33	32	33	43	47	52	45	44	43	41	42	44	39	42	49	62	56
1696	Cudgen	P	77	76	77	85	86	131	120	120	105	126	126	146	161	144	173	176	179	181	197	202
1791	Dungay	P	25	31	28	33	36	29	29	29	35	34	30	34	36	43	48	50	62	62	60	68
1801	Duranbah	P	35	42	38	42	36	33	26	28	23	15	16	24	27	30	27	26	41	41	43	47
1915	Fingal Head	P	38	43	36	40	46	57	48	48	44	37	38	25	39	28	28	44	45	40	34	31
4054	Kingscliff	P	271	248	283	330	325	350	334	348	328	368	397	383	392	418	421	427	460	474	481	468
2687	Murwillumbah	P	493	489	473	462	429	436	411	398	386	380	404	402	423	428	440	454	442	417	388	354
4101	Murwillumbah East	P	287	281	301	326	331	343	345	365	332	352	370	367	406	388	371	372	396	402	377	373
3578	Pottsville Beach	P	111	108	99	88	96	91	80	69	80	84	100	146	164	203	227	242	257	308	333	361
3112	Stokers Siding	P	24	26	31	34	35	27	28	26	27	34	42	52	57	59	44	38	62	60	55	61
3189	Terranora	P	32	44	53	61	68	71	60	74	70	77	89	97	114	148	176	209	225	241	237	231
3277	Tumbulgum	P	69	56	61	58	55	61	68	73	64	75	81	83	67	68	66	74	64	75	66	71
3290	Tweed Heads	P	522	420	398	389	383	392	361	340	370	365	360	349	366	399	378	390	434	441	401	358
4111	Tweed Heads South	P	307	377	436	482	507	488	461	438	396	405	373	363	343	340	377	389	405	400	280	264
3293	Tyalgum	P	41	70	77	79	81	71	85	83	89	85	90	97	119	123	113	109	108	112	108	100
3298	Uki	P	107	99	101	97	117	118	135	161	187	201	228	209	237	234	235	239	265	253	278	298
	TOTAL		2939	2940	3059	3205	3308	3437	3415	3443	3391	3508	3644	3753	4003	4123	4244	4400	4663	4805	4851	4950

The 'Core Plus' System

Correlation Between Changing School Population and Demountable Facilities

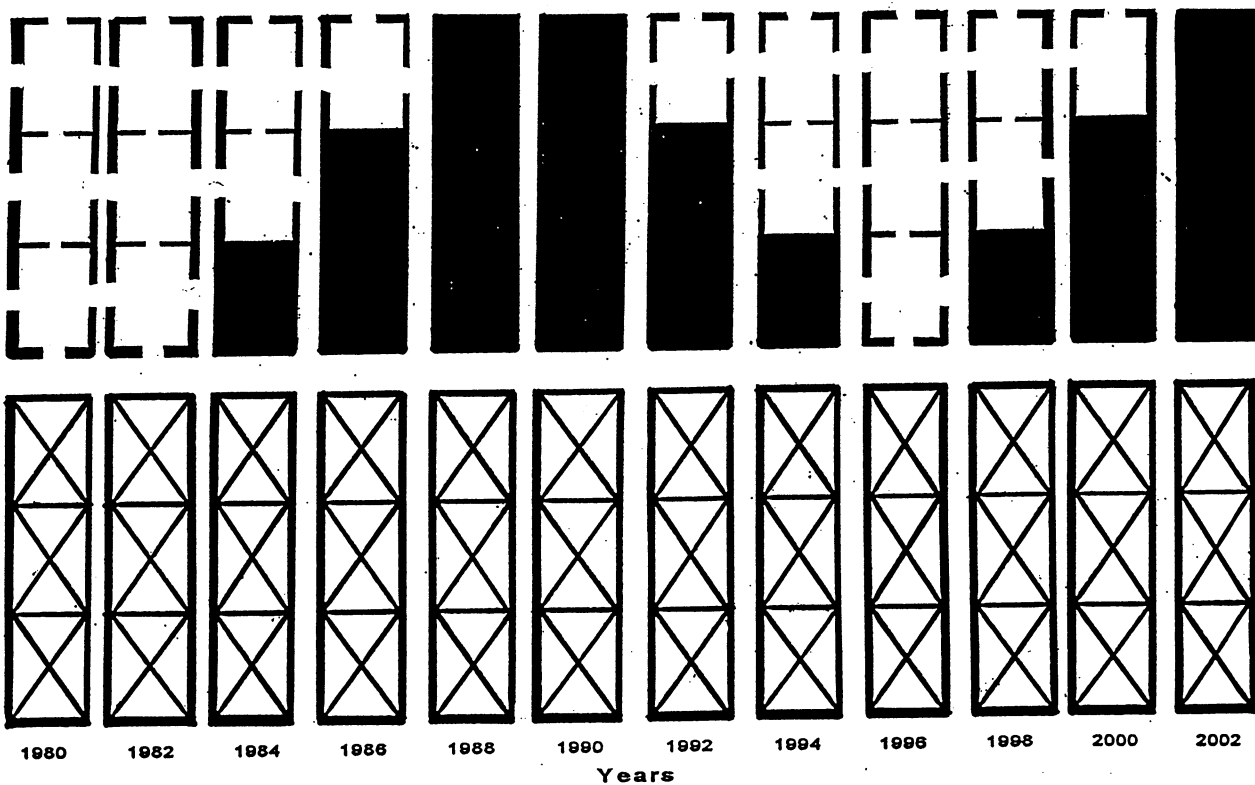
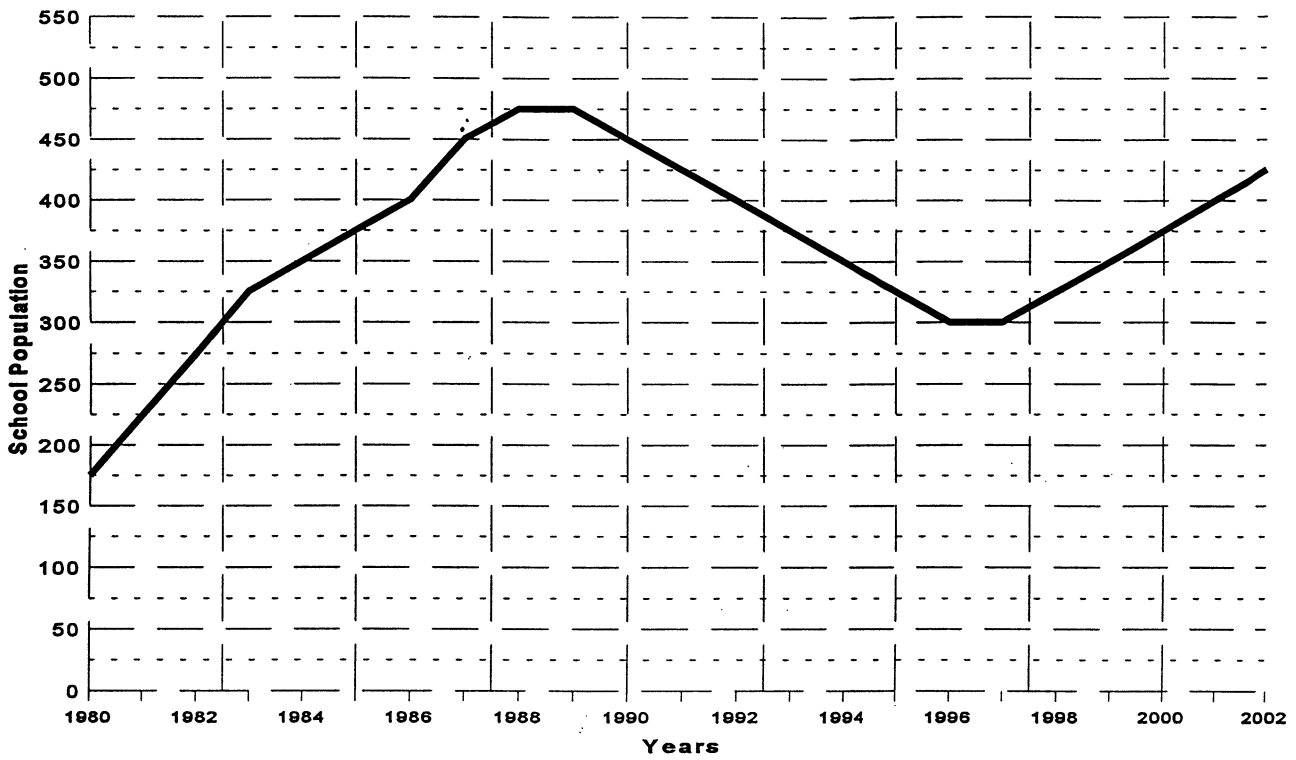

LEGEND:



In situ permanent school buildings.



Demountable school accommodation.

NOTE:

EXAMPLE ONLY - all figures contained in this Graph are hypothetical.

OH 14

BARNSLEY PUBLIC SCHOOL

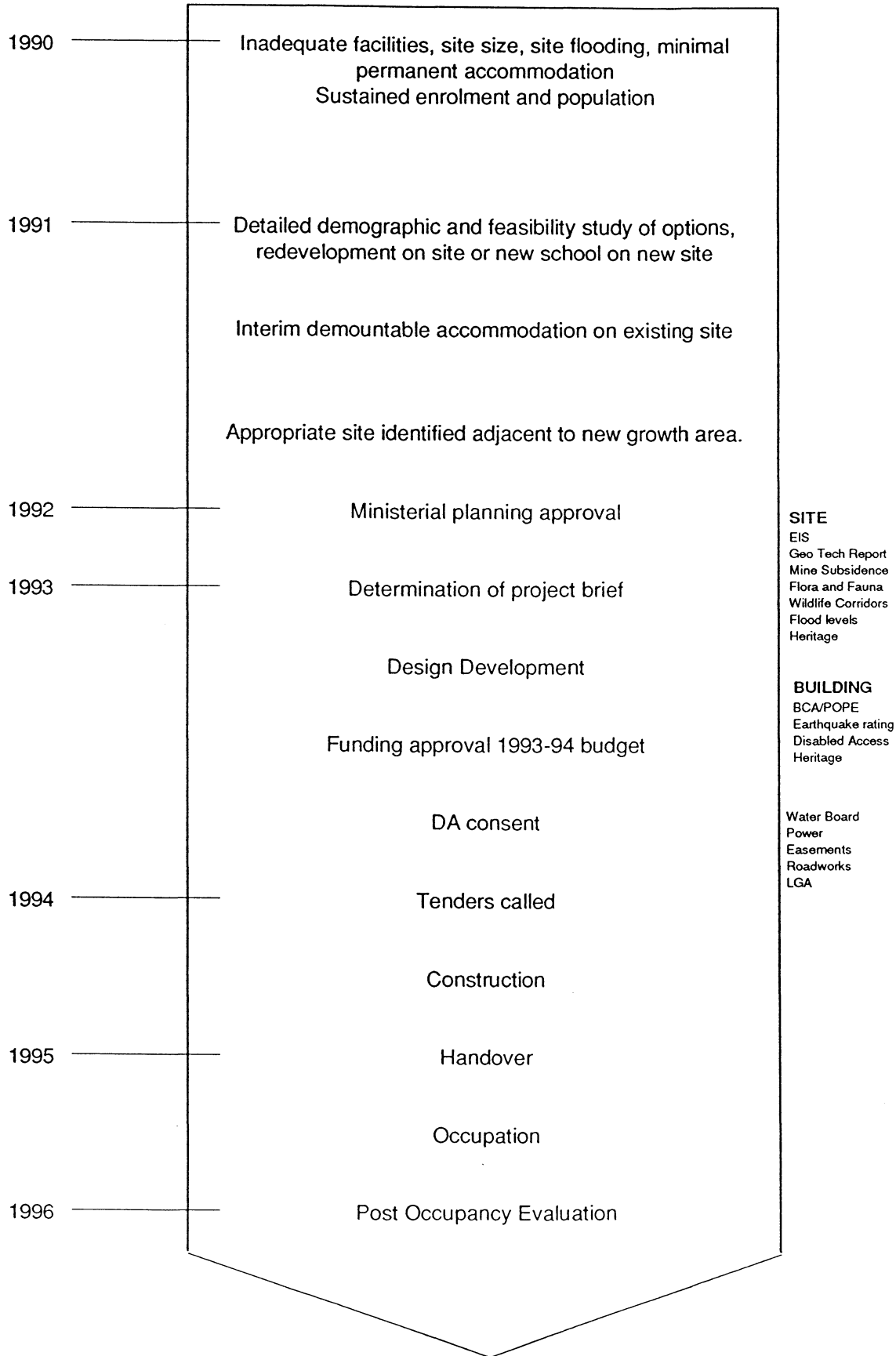

COMPONENT DESIGN RANGE

RESPONSE TO SITE
PLANFORMS: Two types to respond to diverse slope and orientation

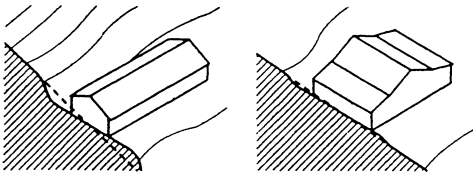

Linear plans suit steep slopes. Square plans suit gentle slopes.

SUBSTRUCTURE: Two types to respond to degree of slope

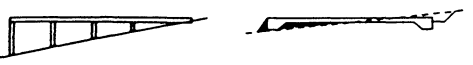

Steep Slopes: suspended floor Gentle Slopes: slab on cut and fill

The Component Design Range comprises selections of building plans, profiles, materials and elements to form a choice based system from which client users and designers can:

- Produce a unique school tailored to an individual site
- Adapt to the specific needs of school and community
- Benefit from the use of pre-designed components based on the most successful examples of recent experience
- Achieve best value for the available budget
- Adopt passive environmental design principles

The range of components, materials and finishes is based on continuing research by the joint P.W.D. and Schools Education Building Research Group to deliver buildings that are functional, economical, easily built, environmentally responsive and innovative solutions.

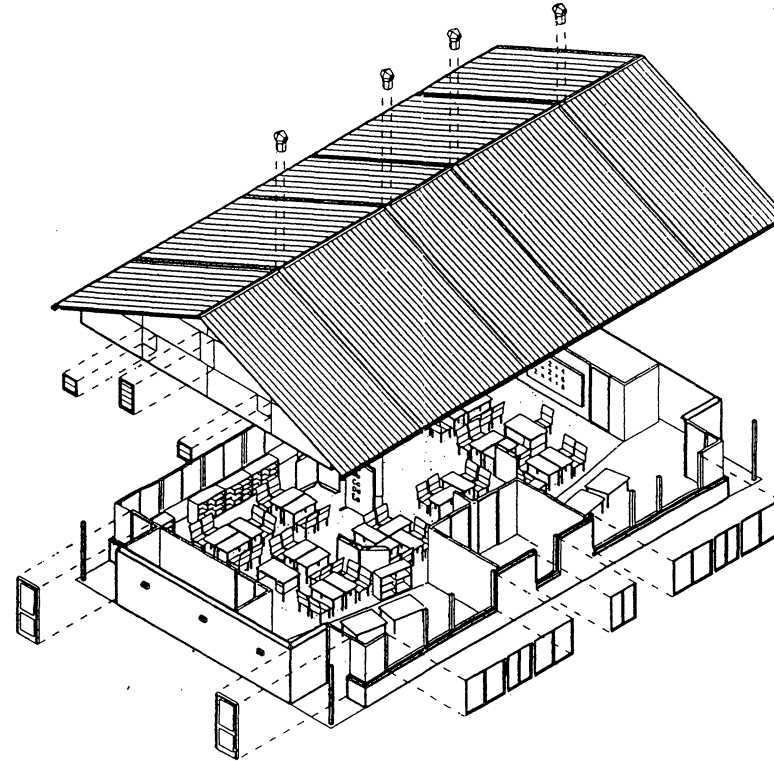

Components come together to form a two classroom unit

CONSTRUCTION OPTIONS

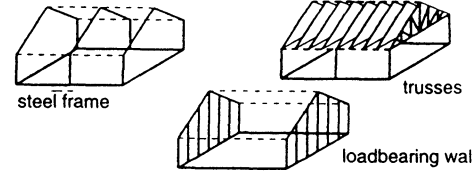

steel frame trusses loadbearing walls

MATERIALS AND ELEMENTS

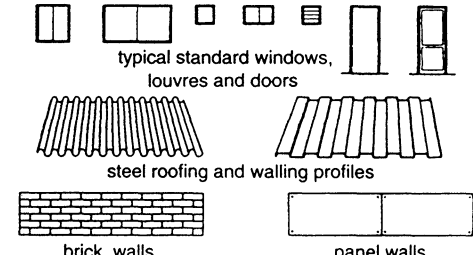

typical standard windows, louvres and doors

steel roofing and walling profiles

brick walls panel walls

RANGE OF PLAN FORMS
 Examples of Administration Building plans

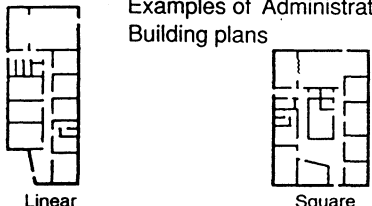

Linear Square

RANGE OF ROOF PROFILES

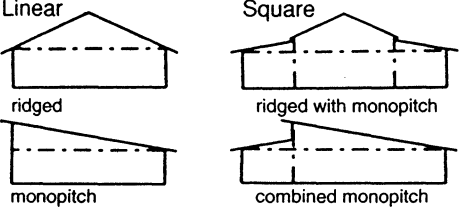

Linear Square

ridged ridged with monopitch

monopitch combined monopitch

BUILDING ELEVATIONS

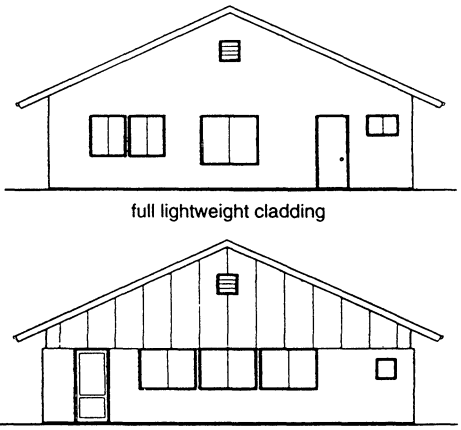

full lightweight cladding

brick to door height, lightweight cladding above

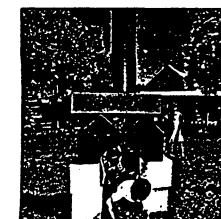
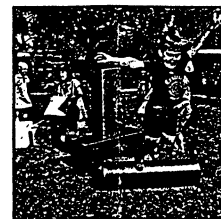

PROCEEDINGS OF THE COMMITTEE

The Proceedings of the Committee for the Inquiry into NSW School Facilities include minutes of all meetings at which this inquiry was considered. It should be noted that this inquiry was not considered at all meetings of the Committee, which conducts multiple concurrent inquiries.

The minutes of the following meetings are relevant to this inquiry and therefore contained in this section: No20, No 23, No 27, No 28, No 35 and No 37.

Minutes of Meeting No.20 - Thursday 27 June 1996 at 11 am

1. Members Present

Mrs Beamer, Mr Crittenden (Chairman), Mr Humpherson, Mr Price, Mr Rixon, Mr Souris, Mr Stewart.

2. Apologies

Ms Nori, Mr Sullivan.

3. Confirmation of Minutes

Minutes of meeting No.19 were agreed to without amendment on motion of Mr Price and seconded by Mr Rixon.

4. Current Inquiries - Lake Illawarra Authority

The Project Officer briefed Members on travel arrangements and itinerary for the site inspection and public hearing in Wollongong.

5. Report on NSW Capital Works Programs

The Chairman reported on the progress of the draft Report and gave notice of a deliberative meeting to consider the Report during the tour to Wollongong on 17-18 July 1996.

Resolved, on the motion of Mr Humpherson, seconded by Mr Rixon, That the Committee incorporate the corrected record of interview with Mr Michael Reid on 13 May 1996 into evidence for inclusion in the First Report on Development and Approval Processes for NSW Capital Works.

6. New Inquiry - NSW School Facilities

The Committee reviewed the Terms of Reference for the Inquiry into NSW School Facilities.

Resolved, on the motion of Mr Rixon, seconded by Mr Stewart, That the Committee approve the Terms of Reference for the Inquiry into NSW School Facilities.

7. National Conference of Parliamentary Public Works Committees

The Project Officer checked Members travel and accommodation arrangements for the Public Works Conference in Canberra on 5-6 August 1996.

Discussion ensued on the most economical and practical methods of dealing with costs for the conference.

Resolved, on the motion of Ms Beamer, seconded by Mr Humpherson, That Members be furnished with daily allowances for the Public Works Conference in Canberra.

8. Staffing

The Chairman advised the Committee of the increasing workload on the Project Officer and proposed appointing a temporary part-time research assistant to the Committee to assist with general research and administrative work now that the Committee was undertaking three simultaneous inquiries.

The Project Officer noted that the Committee currently shared an ACO with the Joint Standing Committee on the Ombudsman and that this economy could be used to provide temporary staff in busy periods.

Resolved, on the motion of Mr Rixon, seconded by Mr Stewart, That Mr Joseph Hanna be appointed as a research assistant to the Committee to assist with general research and administrative work.

9. Next meeting

To be advised.

The meeting adjourned at 11.26 am.

Minutes of Meeting No.23 - Thursday 19 September 1996 at 9.30 am

1. Members Present

Ms Beamer, Mr Crittenden (Chairman), Mr Humpherson, Ms Nori, Mr Price, Mr Souris, Mr Stewart, Mr Sullivan.

2. Apologies

Mr Rixon.

3. Confirmation of Minutes

Resolved, on the motion of Mr Souris, seconded by Mr Humpherson, That the Minutes of Meetings Nos.20-22 be confirmed without amendment.

4. Inquiry into Lake Illawarra Authority

The Chairman advised the Committee that the draft report had been completed and would be circulated to Members on Tuesday, 24 September 1996.

5. **Inquiry into Development and Approval Processes for NSW Capital Works: draft Report**

The draft Report was distributed to Members. It was agreed that a lunchtime deliberative meeting would be held on 26 September 1996 to consider the draft Report.

6. **Inquiry into NSW School Facilities**

The Committee received submissions and background briefing material.

The Committee also considered options for a site inspection. It was agreed that the Project Officer would prepare a draft itinerary for the Committee to inspect schools in Canberra and on the north coast of New South Wales in the second half of October 1996.

7. **Inquiry into Wyong Bus Interchange**

The Committee received submissions and background briefing material.

8. **VHST Proposal**

The Chairman undertook to consult the Minister for Transport on progress regarding this matter and to report to the Committee at the next meeting.

9. **Next Meeting**

Thursday, 26 September 1996, 12 pm.

The meeting adjourned at 10.15 am.

Minutes of Meeting No. 27 - Tuesday 12 November 1996 at 4.30 pm

1. **Members Present**

Ms Beamer, Mr Crittenden (Chairman), Mr Humpherson, Ms Nori, Mr Rixon, Mr Stewart, Mr Sullivan, Mr Windsor.

2. **Apologies**

Mr Price, Mr Souris.

3. **Confirmation of Minutes**

Resolved, on the motion of Ms Beamer, seconded Mr Humpherson, That the minutes of meeting Nos.25 and No.26 be received by the Committee.

Resolved, on the motion of Ms Beamer, seconded Mr Sullivan, That the minutes of meeting

No.26 be corrected.

Resolved, on the motion of Ms Beamer, seconded by Ms Nori, That the minutes of meetings No.25 and No.26 be agreed to as amended.

4. Welcome of Tony Windsor MP

The Chairman formally welcomed Tony Windsor MP to the Committee.

5. Inquiry into Wyong Interchange

The Project Officer reported on progress of the inquiry into Wyong Interchange.

The Chairman advised the Committee of the need for an independent consultant with technical knowledge of the building industry to review costings in relation to this project.

The Project Officer indicated that Mr Richard Olzomer had been approached to act as a consultant to the Committee from 13 November 1996 to 4 December 1996. Mr Olzomer had provided the Committee with a quotation of \$4,480.00 for such a three week contract.

Resolved, on the motion of Ms Beamer, seconded by Mr Rixon, That the Committee request the Clerk to appoint Mr Richard Olzomer as consultant for the Inquiry into Wyong Interchange on a three week contract from 13 November 1996 to 4 December 1996 at a cost of \$4,480.00, subject to corrections in the contract identified by Mr Rixon.

6. Inquiry into NSW School Facilities

The Project Officer advised that a public hearing should be scheduled for the Inquiry into NSW School Facilities.

Resolved, on the motion of Ms Beamer, seconded Mr Humpherson, That the Project Officer schedule a public hearing in the first week of December in consultation with Members, subject to the sitting dates of Parliament.

7. Staffing

The Chairman advised the Committee of a reduction in staffing levels. It was noted that the Committee had two current inquiries with a proposed completion time frame of Christmas 1996.

It has been proposed to the Committee that Ms Amanda Olsson be appointed as a Research Officer for the Inquiry into NSW School Facilities.

Resolved, on the motion of Ms Beamer, seconded Mr Rixon, That the Committee request the Clerk to appoint Ms Amanda Olsson at Grade 6 (casual) level for the duration of the Inquiry into NSW School Facilities, subject to her availability.

8. Next Meeting

To be determined.

The meeting adjourned at 5.04 pm.

Minutes of Meeting No.28 - Thursday 20 February 1997 at 9.20 am

1. Members Present

Mrs Beamer, Mr Crittenden (Chairman), Mr Humpherson, Mr Price, Mr Rixon, Mr Sullivan, Mr Windsor.

2. Apologies

Mr Hunter, Mr Souris, Mr Stewart.

3. Public Hearings

The public were admitted.

Mr David Rowland, Director (Properties), Department of School Education, affirmed and examined.

Evidence concluded, the witness withdrew.

Mr John Kimball, National Education Marketing Manager, James Hardie Industries, affirmed and examined. Tabled document, "Education Facilities and the Emergence of the Fourth Generation Systems Built Schools Industry".

Evidence concluded, the witness withdrew.

Mr Tony O'Donnell, sworn and examined. Tabled document, "Holy Spirit Primary School, Nicholls: Catholic Education Office Joint Venture with the ACT Government".

Evidence concluded, the witness withdrew.

Mr David Muddiman, affirmed and examined. Tabled photographs, plans and document, "North Coast Standard School Buildings: Barkers Vale Public School - 1991".

Evidence concluded, the witness withdrew.

Mr John Zahn, Schools Section Manager, Department of Public Works and Services, sworn and examined.

Evidence concluded, the witness withdrew.

4. Confirmation of Minutes

Resolved, on the motion of Mr Price, seconded Mr Rixon, That the minutes of meeting No.27 of 12 November 1996 be received by the Committee.

5. Appointment of Mr Jeff Hunter MP

The Committee noted the appointment of Mr Jeff Hunter MP.

6. Inquiry into Wyong Interchange

The Committee received the response of the Department of Transport to Questions on Notice and a report on it by the consultant, Mr Richard Olzomer.

Resolved, on the motion of Mr Rixon, seconded Mr Price, that a public hearing be held for the Inquiry into Wyong Interchange with the consultant, Mr Richard Olzomer, and representatives of the Department of Transport.

7. Inquiry into Development and Approval Processes for NSW Capital Works

The Committee considered the proposed schedule for the next stages of this inquiry involving two full day briefing sessions with a view to completing two reports by the end of June 1997.

Resolved, on the motion of Mr Humpherson, seconded Mr Price, that the Project Officer organise briefings for the next two stages of the Inquiry into Development and Approval Processes for NSW Capital Works.

8. 1997 National Conferences of Australian Parliamentary Public Works and Environment Committees: 14-16 July 1997

The Committee considered correspondence from the Chairman of the Queensland Public Works Committee, Mr Len Stephen MP, containing the proposed dates of 14-16 July 1997 for this year's successive Environment and Public Works Conferences in Brisbane.

The Committee discussed the possibility of New South Wales hosting the 1998 Conference and noted the considerable ongoing duties for staff involved in its organisation.

The Committee deliberated on the possibility of conducting a seminar on an infrastructure-related subject (such as the Sydney 2000 Olympics) as part of the conferences.

Resolved, on the motion of Mr Price, seconded Mr Rixon, that:

- That the Chairman reply to the Chairman of the Queensland Public Works Committee on behalf of the Committee confirming attendance at the 1997 Public Works and Environment Conferences in Brisbane.
- That the Committee agree to host the 1998 Public Works and Environment Conferences at the New South Wales Parliament.
- That the Committee approve the concept of a fee-paying public seminar as part of the 1998 conference schedule and clearly state this goal when accepting the host role.
- That the Committee agree in principle to the addition of a senior staff person to organise the 1998 conferences and related seminar and request the Clerk of the Legislative Assembly to consider this matter.

9. Correspondence

The Committee discussed a letter from the Hon. Elisabeth Kirkby MLC regarding a proposed inquiry into the North West (Rouse Hill) Sector.

Resolved, on the motion of Mr Humpherson, seconded Mrs Beamer, That the Chairman write to Ms Kirkby stating that her request will be considered amongst the Committee's other priorities.

10. General Business

The Committee requested the Project Officer to organise a briefing from departmental officers on the current status of the Very High Speed Train (VHST) proposal.

11. Next Meeting

To be determined.

The meeting adjourned at 3.15 pm.

Minutes of Meeting No.35 - Tuesday 14 October 1997 at 4.15 pm

1. Members Present

Mr Crittenden (Chairman), Mrs Beamer, Mr Hunter, Mr Price, Mr Rixon, Mr Souris, Mr Stewart, Mr Sullivan, Mr Windsor.

2. Apologies

Mr Humpherson.

3. Confirmation of Minutes

Resolved, on the motion of Mr Price, seconded Mr Sullivan, That the minutes of Meetings 32-34 of 17 April, 16 June and 25 June 1997 be received by the Committee.

4. Report on the National Conference of Parliamentary Public Works and Environment Conferences, Brisbane 1997

The Committee considered the draft report.

Resolved, on the motion of Mr Price, seconded Mr Rixon, That the draft report be the Report of the Committee and that it be signed by the Chairman and presented to the House, together with minutes of meetings and evidence.

Resolved, on the motion of Mr Stewart, seconded by Mr Windsor, That the Chairman and Director be permitted to correct any incidental stylistic or typographical errors that are identified while preparing the Report for printing.

5. Inquiry into the Tilt Train

The Committee considered the Queensland tilt train project in its Report on the National Conference of Parliamentary Public Works and Environment Conferences, Brisbane, 1997.

Resolved, on the motion of Mr Sullivan, seconded Mr Rixon, That the Committee conduct an inquiry into and report on the feasibility of tilt train technology for NSW inter-urban and regional rail services.

6. Regional Centres in Transition

The Committee considered options for a series of new inquiries which would focus on infrastructure priorities in regional NSW to meet the changing economic and employment landscape under the title "Regional Centres in Transition."

Resolved, on the motion of Mr Sullivan, seconded Mr Windsor, That the Committee defer consideration of "Regional Centres in Transition" until current reports were processed.

7. Proposed Joint Inquiry with Public Bodies Review Committee

The Committee discussed correspondence from the Chairman of the Public Bodies Review Committee (27 June 1997) suggesting the possibility of a joint inquiry on contract tendering analysis by public bodies in NSW.

Mr Sullivan - as a Member of both Committees - outlined progress on this project and suggested that a briefing paper being prepared by the Public Bodies Review Committee be made available to the Committee prior to any decision to proceed.

The Committee discussed the feasibility of addressing the issue of security of payment for subcontractors in such an inquiry and requested that the secretariat prepare a briefing paper for the next meeting.

8. National Conference of Parliamentary Public Works and Environment Committees, Sydney 1998

The Committee discussed conference options including timing, structure and costs.

Resolved, on the motion of Mr Price, seconded Mr Sullivan, That the National Conference of Public Works Committee be held over two days and Environment Conferences be held over one day concurrently in the last week of July 1998, subject to consultation with other Committees.

9. Correspondence

The Committee noted incoming correspondence from the Minister for Urban Affairs and Planning, the Hon Craig Knowles MP, dated 7 July 1997.

The Committee noted outgoing correspondence from the Chairman to the Hon Elisabeth Kirkby MLA (9 May 1997) and the Minister for Urban Affairs and Planning, the Hon Craig Knowles MP (23 July 1997).

Resolved, on the motion of Mr Price, seconded Mrs Beamer, that incoming and outgoing correspondence be noted.

10. Report on NSW School Facilities

Mr Stewart took the Chair due to the Chairman's commitments in the House. The Committee considered the draft report.

Recommendations

Recommendation 5 - agreed to as amended

Resolved, on the motion of Mr Rixon, seconded Mr Price, That the Recommendations be adopted as amended.

Resolved, on the motion of Mr Rixon, seconded Mr Price, That the Executive Summary be adopted.

Resolved, on the motion of Mr Souris, seconded Mr Rixon, That Chapters 1-4 be adopted.

Resolved, on the motion of Mr Price, seconded Mr Rixon, That the draft report be the Report of the Committee and that it be signed by the Chairman and presented to the House, together with minutes of meetings and evidence.

Resolved, on the motion of Mr Price, seconded by Mr Souris, That the Chairman and Director be permitted to correct any incidental stylistic or typographical errors that are identified while preparing the Report for printing.

Resolved, on the motion of Mr Rixon, seconded Mr Sullivan, That the Chairman write to the DSE officers, Mr David Muddiman and Mr David Rowland, on behalf of the Committee thanking them for their assistance during the inquiry and commending them and their staff for their work.

The Committee thanked staff for their work on this inquiry.

11. Next Meeting

To be determined.

Meeting adjourned at 5.45 pm

Minutes of Meeting No.37 - Tuesday 11 November 1997 at 4.30 pm

1. Members Present

Mr Crittenden (Chairman), Mr Price, Mr Rixon, Mr Souris, Mr Stewart, Mr Sullivan, Mr Windsor.

2. Apologies

Mrs Beamer, Mr Humpherson, Mr Hunter.

3. Confirmation of Minutes

Resolved, on the motion of Mr Souris, seconded Mr Stewart, That the minutes of Meeting No.36 of 21 October 1997 be received by the Committee.

4. Report on NSW School Facilities - Recommittal

The Committee discussed recommitting the Report to consider amendments which would clarify the meaning of some sections.

Resolved, on the motion of Mr Price, seconded Mr Stewart, That the *Report on NSW School Facilities* be recommitted to reconsider the recommendations and to consider adding a further section to the Report.

Resolved, on the motion of Mr Price, seconded Mr Windsor, That Recommendation 7 be agreed to as amended.

Resolved, on the motion of Mr Price, seconded Mr Stewart, That Section 2.2.2 be adopted for inclusion in the Report as well as minor amendments resulting from the inclusion of Section 2.2.2.

Resolved, on the motion of Mr Sullivan, seconded Mr Souris, That the amended draft Report be the Report of the Committee and that it be signed by the Chairman and presented to the House, together with minutes of meetings and evidence.

5. Inland Water Diversion

The Committee discussed existing and proposed inland water diversion schemes around Australia and their potential applicability to New South Wales.

Staff were requested to undertake further research on this matter including liaison with the NSW Department of Land and Water Conservation.

Resolved, on the motion of Mr Windsor, seconded Mr Price, That the Committee investigate the Ord River and proposed Fitzroy River inland diversions in Western Australia.

6. Next Meeting

To be determined.

Meeting adjourned at 5.01 pm.

LIST OF SUBMISSIONS

- 1. Australian Earth Environmental Services**
- 2. Trevor Somerville, Principal, Menai Primary School**
- 3. Gary T Smith**
- 4. Menai Primary School Council**
- 5. NSW Teachers Federation**
- 6. NSW Primary Principals' Association**
- 7. Joint Submission from Department of School Education and Department of Public Works and Services**
- 8. James Hardie Building Systems**
- 9. NSW Secondary Principals' Council**

LIST OF WITNESSES

- 1. Mr David Rowland, Director of Properties, Department of School Education**
- 2. Mr John Kimball, Market Development Manager Education, James Hardie Building Systems Pty Ltd**
- 3. Mr Tony O'Donnell, Planning Officer, Catholic Education Office, Archdiocese of Canberra and Goulburn**
- 4. Mr David Muddiman, Manager, Lismore District Office, Department of School Education**
- 5. Mr John Zahn, Schools Section Manager, Department of Public Works and Services**

LIST OF SOURCES

ATF Research Notes

Capital Works Needs in Education, No.12, November 1985.

Australian Bureau of Statistics

Demography of New South Wales 1994, Catalogue No. 3311.1. This report was embargoed until 31 May 1996.

Estimated Resident Population by Age and Sex in Statistical Local Areas in New South Wales, Catalogue No. 3209.1, June 1995.

Projections of the Populations of Australia, States and Territories, 1995-2051, Catalogue No. 3222.0, July 1995.

Australian Education Council

Comparative Capital Costs of Government and Non-government Schools in Australia, Canberra, April 1978

National Report on Schooling in Australia 1990, Carlton, 1991.

Technology - A Curriculum Profile for Australian Schools, Carlton, 1994.

The 1983 Cost Study: The Comparative Capital Costs of Australian Schools, Canberra, August 1983.

Beck, Tinsley

An Australian Study of School Environment in The Australian Journal of Education, No.1, March 1980.

Chapman, Judith (ed)

School-based Decision-making and Management, Hampshire, 1990.

Clyne, Roger

Adaptability and Flexibility in Educational Facilities, 1990. Conclusions of a seminar held by the Organisation for Economic Co-operation and Development in Leicester, United Kingdom 19-22 June 1989.

Commonwealth Schools Commission

Planning School Building Projects, Canberra, October 1981.

School Building Needs - New Places, Canberra, November 1984.

Schools Design and Use, Canberra, 1982.

Directorate of School Education

A Quality Provision Framework for Victorian Schools, 1993.

Environmental Design Unit, Department of Public Works and Services

Designs on the Environment in In Focus, Government Officer, February 1996.

Holcomb, Dr John H.

A Guide to the Planning of Educational Facilities (Third Edition), Lanham, 1992.

Isles, Tim

Time to Save Energy in Education News

McRae, David

The Integration/Inclusion Feasibility Study, Sydney, October 1996.

National Youth Affairs Research Scheme & Australian Bureau of Statistics

New South Wales' Young People : A Statistical Profile, Catalogue No. 4123.1, September 1993.

National Board Employment, Education and Training

Developing Indicators for Infrastructure Needs in Secondary Schools, Report No. 31, Australian Government Publishing Service, August 1994

NSW Department of Education

Government Schools of New South Wales 1848 to 1993, Sydney, 1993.

Schools Renewal: A Strategy to Revitalise Schools within the New South Wales State Education System, Milsons Point, June 1989.

Sydney and the Bush, 1980.

NSW Department of School Education & NSW Department of Public Works

A Partnership for the Delivery of Maintenance to Schools in New South Wales - A Working Document for the 1994/95 Financial Year, 1994.

Component Design Range User Manual, December 1994.

NSW Department of School Education

Education 2000, Sydney, 1992.

Policy and Procedures for Joint Funding of Capital Works in Schools, January 1996.

Procedures by Which Public Works Projects are Developed and Processed, May 1996. Presentation to the Standing Committee on Public Works.

NSW Department of Education & NSW Department of Public Works

Working Agreement Between Department of School Education and Department of Public Works & Services, June 1996.

NSW Department of Planning

Cities For The 21st Century, Sydney, January 1995.

North Coast Urban Planning Strategy into the 21st Century, Sydney, January 1995.

Population Projections : Non-Metropolitan Local Government Areas in New South Wales 1991-2021, Sydney, August 1994.

NSW Public Accounts Committee

Matters Arising from the NSW Auditor-General's Report 1995, Report No. 11/51, 1996.

NSW Standing Committee on Public Works

State Infrastructure Requirements for Sydney West Airport, Report No. 1, 1995.

First Report on Development and Approval Processes for NSW Capital Works, Report No.2, 1996.

Ortiz, Flora Ida:

School Housing: Planning and Designing Educational Facilities, State University of New York Press, New York, 1994.

Parliament of New South Wales

NSW Department of Education Annual Report for the Year Ended 31 December 1987, 1988.

NSW Department of Education Annual Report for the Year Ended 31 December 1988, 1989.

NSW Department of Education Annual Report for the Year Ended 31 December 1989, 1990.

NSW Department of Education Annual Report for the Year Ended 31 December 1990, 1991.

NSW Department of Education Annual Report for the Year Ended 31 December 1991, 1992.

NSW Department of Education Annual Report for the Year Ended 31 December 1992, 1993.

NSW Department of School Education Annual Report for the Year Ended 31 December 1993, 1994.

NSW Department of Education Annual Report for the Year Ended 31 December 1994, 1995.

NSW Department of School Education Annual Report 1994: Financial Statements & Appendices, 1995.

NSW Department of Education Annual Report for the Year Ended 31 December 1995.

Planning Unit, NSW Department of School Education

Recent Demographic Trends in NSW: Implications for School Education, No.1, June 1993.

Power, Colin

Open Area Schools: Stone Walls Do/Do Not? in South Australian Journal of Education Research, Vol. 1, No. 3, 1981

Sachs, Judith

Computer Education in Australia: What is the Direction of Policy? in Unicorn, Vol. 19, March 1993.

Schools Building Research & Development Group

Schools Information System: Design Guide, Document SIS 6, November, 1994.

Schools Facilities Standard: Primary School Facilities Standard Supplement 1 (Special Facilities), June 1995.

Schools Facilities Standard: Secondary School Facilities Standard, June 1995.

Schools Facilities Standards: Specification Guide (Part 1 of 3), May 1996.

Schools Facilities Standards: Specification Guide (Part 2 of 3), May 1996.

Schools Facilities Standards: Specification Guide (Part 3 of 3), May 1996.

The Audit Office of New South Wales

Performance Audit Report: Department of School Education: Effective Utilisation of School Facilities, Sydney, September 1995.

The Management Review: New South Wales Education Portfolio

School Centred Education - Building a More Responsive State School System Sydney, March 1990.

Underwood, F.D.

Public School Architecture in New South Wales: Secondary Schools in NSW - Ten Years of Progress, Sydney, 1972.

Wills, Ian

The Ecologically Sustainable Development Process: An Interim Assessment in Policy, Spring, 1992.

White, Doug

Implications of Demographic Change for Education in New South Wales, August 1982. This paper was presented to the New South Wales Section of the Australian Population Association on the 24 August 1982.

Uses of Demography in the Public Sector, June 1996.

Participation in Education, May 1996. This paper is an update of a paper that was presented to the Ninth National Australian Population Conference, Canberra, September 1994.

LIST OF TABLES

- Table 1: Core Plus Planning Principles**
- Table 2: DSE/DPWS Strategic Planning & Development**
- Table 3: Changes in Enrolments by NSW Region**
- Table 4: Changes to Student Enrolments 1950 -2002**
- Table 5: Projected Population Change 1991 - 2001, NSW Statistical Division**
- Table 6: Intrastate Migration NSW, 1981 - 1986**
- Table 7: Students & Demountables by Region - 1995**
- Table 8: Annual Demountable Funding 1994 - 1997**
- Table 9: Trends in Demountable Movements, 1987-88 to 1996-97**
- Table 10: Cost of Installing ESD Features in Demountables**
- Table 11: Demountables - Survey of Deficiencies**
- Table 12: Comparison of Costs for Lightweight School Buildings & Project Homes**
- Tables 13: Net Present Value Costs of Primary School Homebases Over 50 Years**
- Table 14: Projected Enrolments - Holy Cross Primary School, ACT**

LIST OF ACRONYMS AND ABBREVIATIONS

AASA	-	American Association of School Administrators
ACT	-	Australian Capital Territory
CDR	-	Component Design Range
CEO	-	Catholic Education Office
COLA	-	Covered Outdoor Learning Area
DA	-	Development Application
DPWS	-	Department of Public Works and Services
DSE	-	Department of School Education
DUAP	-	Department of Urban Affairs and Planning
ESD	-	Ecologically Sustainable Development
LAN	-	Local Area Network
LGA	-	Local Government Area
MUIM	-	Ministry for Urban Infrastructure Management.
NBEET	-	National Board of Employment, Education and Training
NCK	-	North Coast Kit
NPV	-	Net Present Value
NSESD	-	National Strategy for Ecologically Sustainable Development
NSWPPA	-	New South Wales Primary Principals' Association
OA LAN	-	OASIS Administration Network
OL LAN	-	OASIS Library Network
OASIS	-	Office Automation and School Information System
OH&S	-	Occupational Health and Safety

POE	-	Post Occupancy Evaluation
PS	-	Public School
SBDRG	-	School Building Design and Research Group
SSP	-	Schools for Specific Purposes
UDP	-	Urban Development Program
UIMP	-	Urban Infrastructure Management Plan
UMCC	-	Urban Management Committee of Cabinet

GLOSSARY

Component Design Range

A system of lightweight buildings used predominantly in NSW primary schools. The CDR has become the standard design used by the DSE in primary schools because of its capacity to allow greater diversity in planning.

CDR's are single story in construction and comprise brick veneer walls, concrete ground slab, metal roof cladding to pitched roof framing, internal stud partitions and aluminium.

Ecologically Sustainable Development

Development that uses, conserves and enhances the community's resources so that ecological processes, on which life depends, are maintained and the total quality of life, now and in the future, can be increased.

Ministry Urban Infrastructure Management

This Ministry has been created to coordinate and integrate infrastructure planning and expenditure in the Sydney Region by establishing clear linkages between urban management strategies, infrastructure planning and provision, and the budgetary process.

North Coast Kit

Lightweight single storey buildings which have been jointly developed by the North Coast regional offices of the DSE and DPWS, in order to meet the harsh climate of the NSW Far North Coast.

The construction of NCK's utilises treated timber frames, a suspended timber floor on brick piers, metal roof cladding, internal stud partitions, aluminium windows, with exterior walls clad in either brick veneer, colorbond or Hardiplank.

Net Present Value

Refers to the life-cycle costs of a building including construction and general maintenance. These costs are then projected for the anticipated life span of the building, with a final 'net present value' outlined in present day dollars.

Post Occupancy Evaluation

A review mechanism used to confirm design utility and to identify areas where refinement is necessary. The review is conducted by appraising the responses of facility users to a Questionnaire developed by the Schools Building Research and Development Group.

Urban Management Committee of Cabinet

This Cabinet Committee brings together ministers with responsibility for most infrastructure delivery in NSW with ministers who look after the welfare of the environment and the community at large.

The Committee aims to improve the planning, delivery and maintenance of infrastructure in the Greater Metropolitan Region of Sydney, Newcastle and Wollongong.

LIST OF MAPS

- 1. Pottsville Beach Public School**
- 2. Centaur Public School**
- 3. Terranora Public School**
- 4. Holy Spirit Primary School, Nicholls, ACT**
- 5. Air Flow through a CDR Lightweight Classroom**
- 6. Home Base Kit building - Perspective Plan**
- 7. Home Base Kit building - Section**
- 8. Home Base Kit building - Floor Plan**

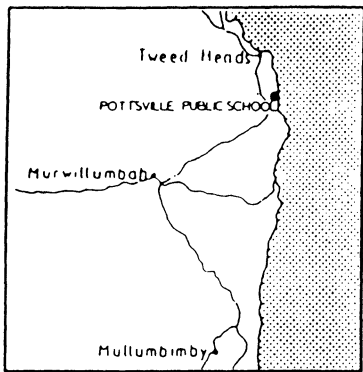

REGION

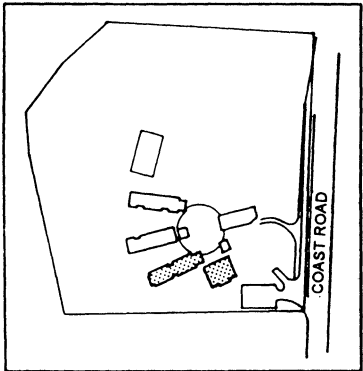

SITE PLAN

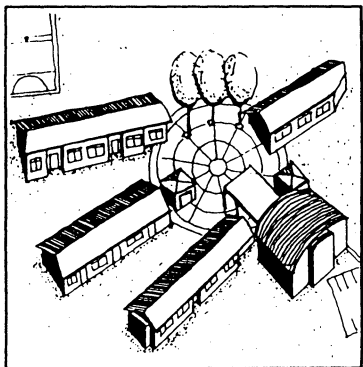

SKETCH

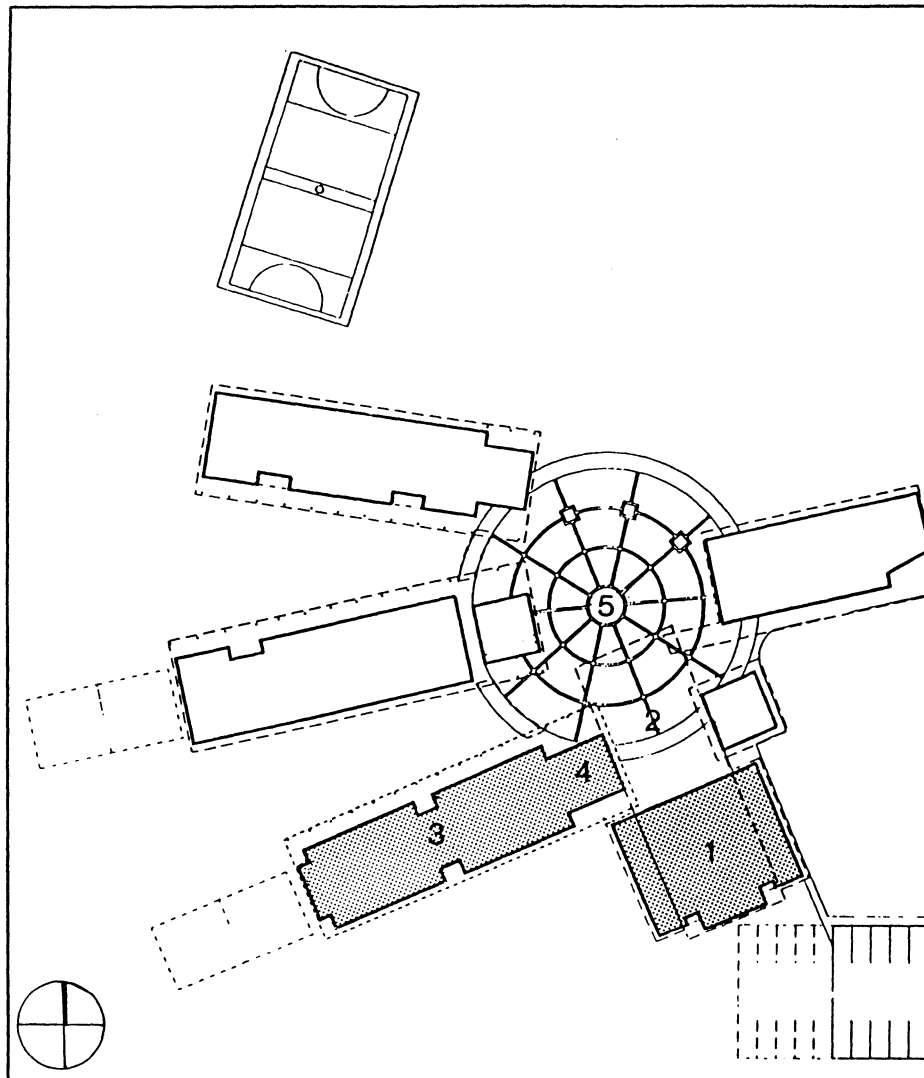
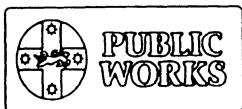

POTTSVILLE PUBLIC SCHOOL STAGE TWO

REGION: North Coast
 ASSISTANT D-G: Mr. Alex Scott
 LOCAL MEMBER: Mr. Don Beck
 ELECTORATE: Murwillumbah
 CONSTR. BUDGET: \$826,000

SPECIAL INTEREST:

Stage One involved the construction of sufficient facilities to allow operation of the school. Stage Two involves building the communal hall, four additional classrooms and additional toilets. The site is placed amongst picturesque scenery and will eventually include a secondary school.

ACCOMMODATION:

- 1. Hall
- 2. COLA
- 3. Homebases
- 4. Toilets
- 5. Assembly

PLANNING PROGRESS REPORT 1994-95 PROGRAM. JANUARY 1995

DEPARTMENT OF SCHOOL EDUCATION



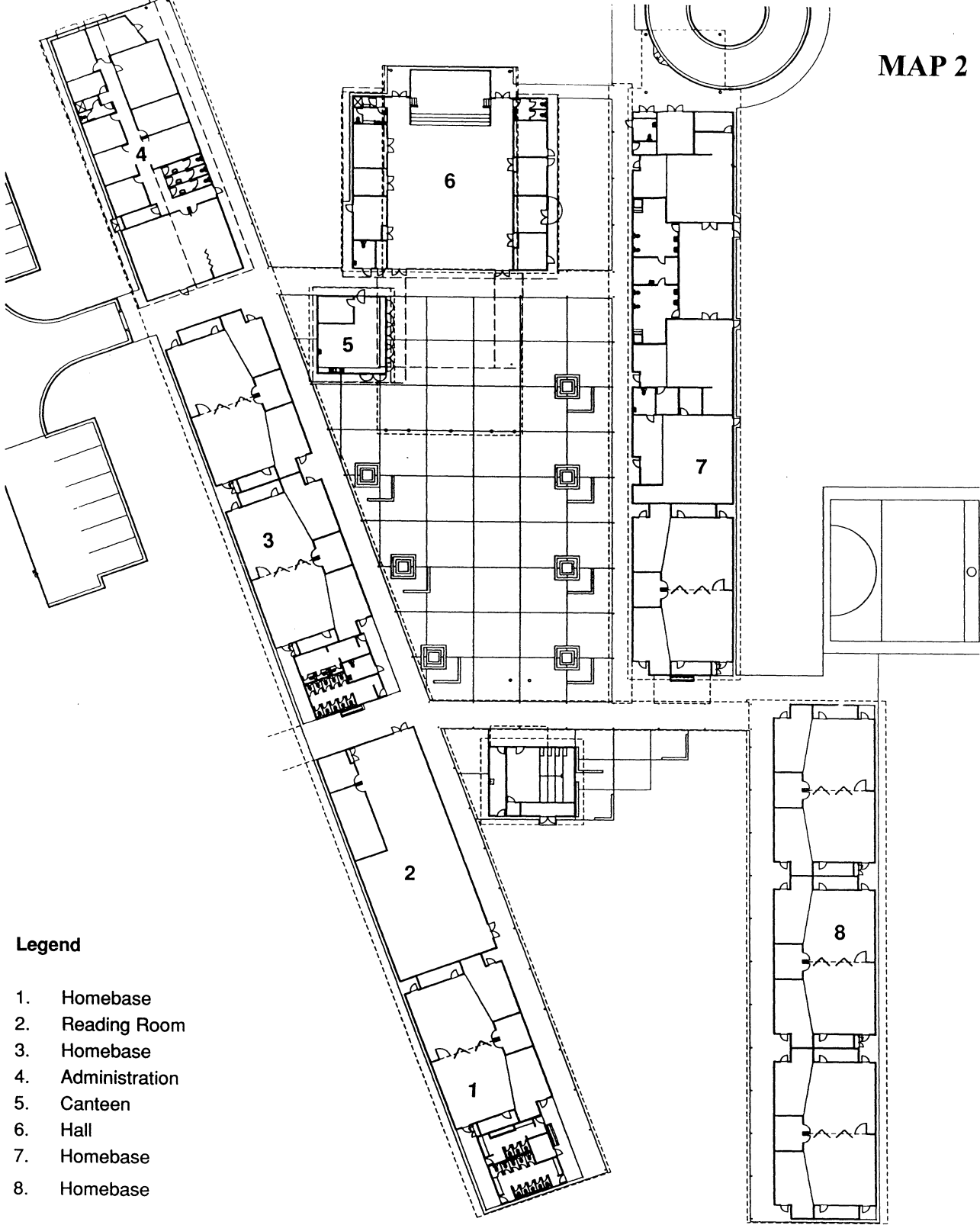

Legend

- 1. Homebase
- 2. Reading Room
- 3. Homebase
- 4. Administration
- 5. Canteen
- 6. Hall
- 7. Homebase
- 8. Homebase





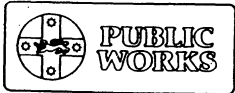

Department of School Education







For further information contact Schools Building Research & Development Group
Level 20 McKell Building Rawson Place Sydney NSW 2000
Telephone (02) 372 8511 Facsimile (02) 372 8566

EXISTING DEVELOPMENT

-  STAGE 1 - BLOCK C - HOMEBASES
-  STAGE 2 - BLOCKS D & H - HOMEBASES
-  STAGE 3 - BLOCKS A,E & G - ADMIN.LIBRARY, & HOMEBASES PLUS COVERED LINKS
-  STAGE 4 - BLOCK B-HALL & PAVING

PROPOSED STAGE 5 DEVELOPMENT

-  STAGE 5 - CANTEEN C.O.L.A. TOILETS
-  STAGE 5 - NEW PAVED AREAS
-  AREAS SET ASIDE FOR SCHOOL TO LANDSCAPE
-  NEW TREES BY SCHOOL

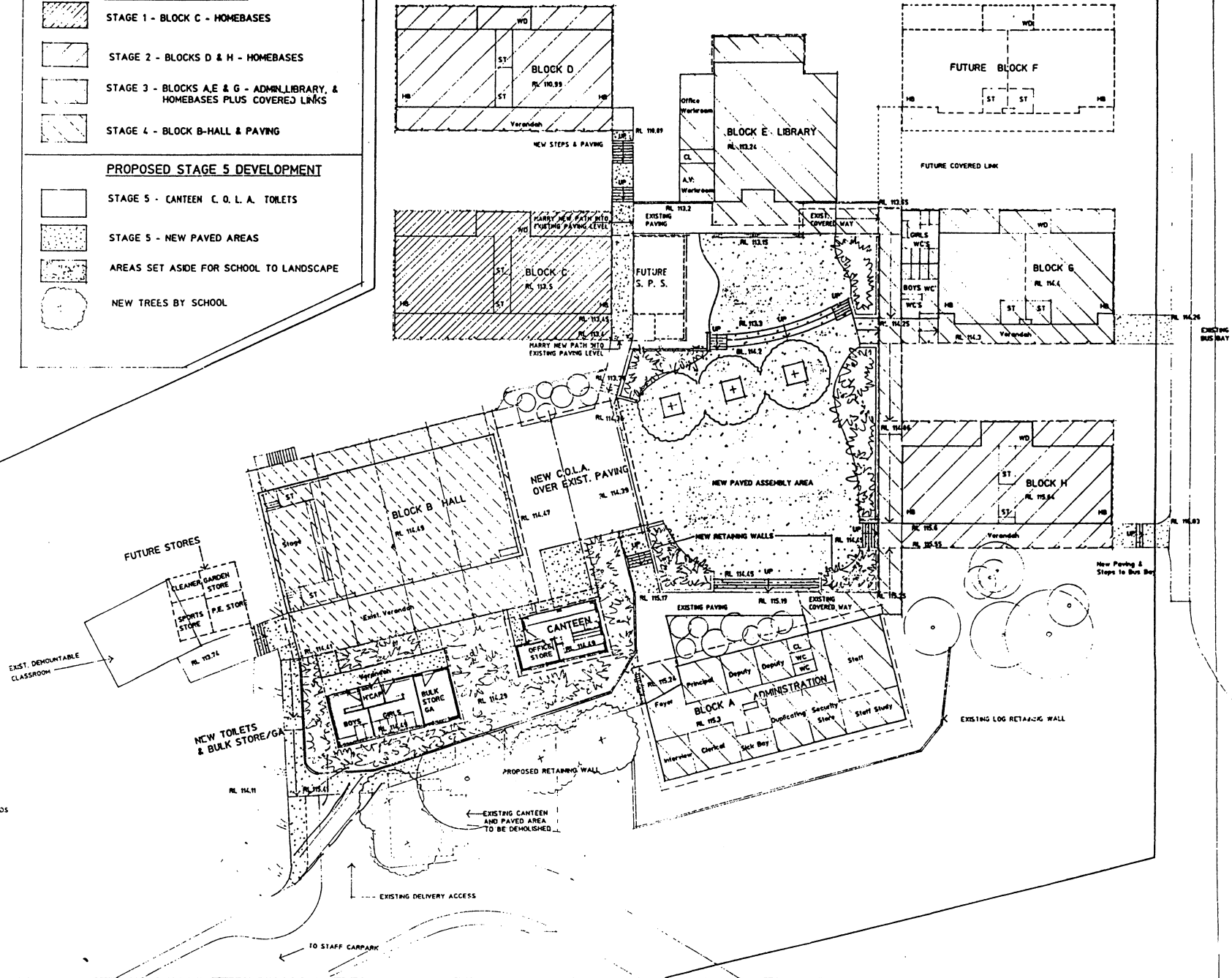

MAP 3

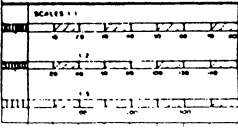

NOTES

DPWS
 Department of Public Works and Services
 State of New South Wales
 NORTH COAST REGION
 CHRIS JOHNSON
 Government Architect
 CLYDE MANUELL
 Municipal Government Architect

TERRANORA PUBLIC SCHOOL
 PROPOSED STAGE 5
 NEW T.L.S. CANTEEN, C.O.L.A. & TOILETS
 DEVELOPMENT PLAN

LA 701	1
1:200	
DATE	1990
SCALE	1:200
PROJECT	TERRANORA PUBLIC SCHOOL

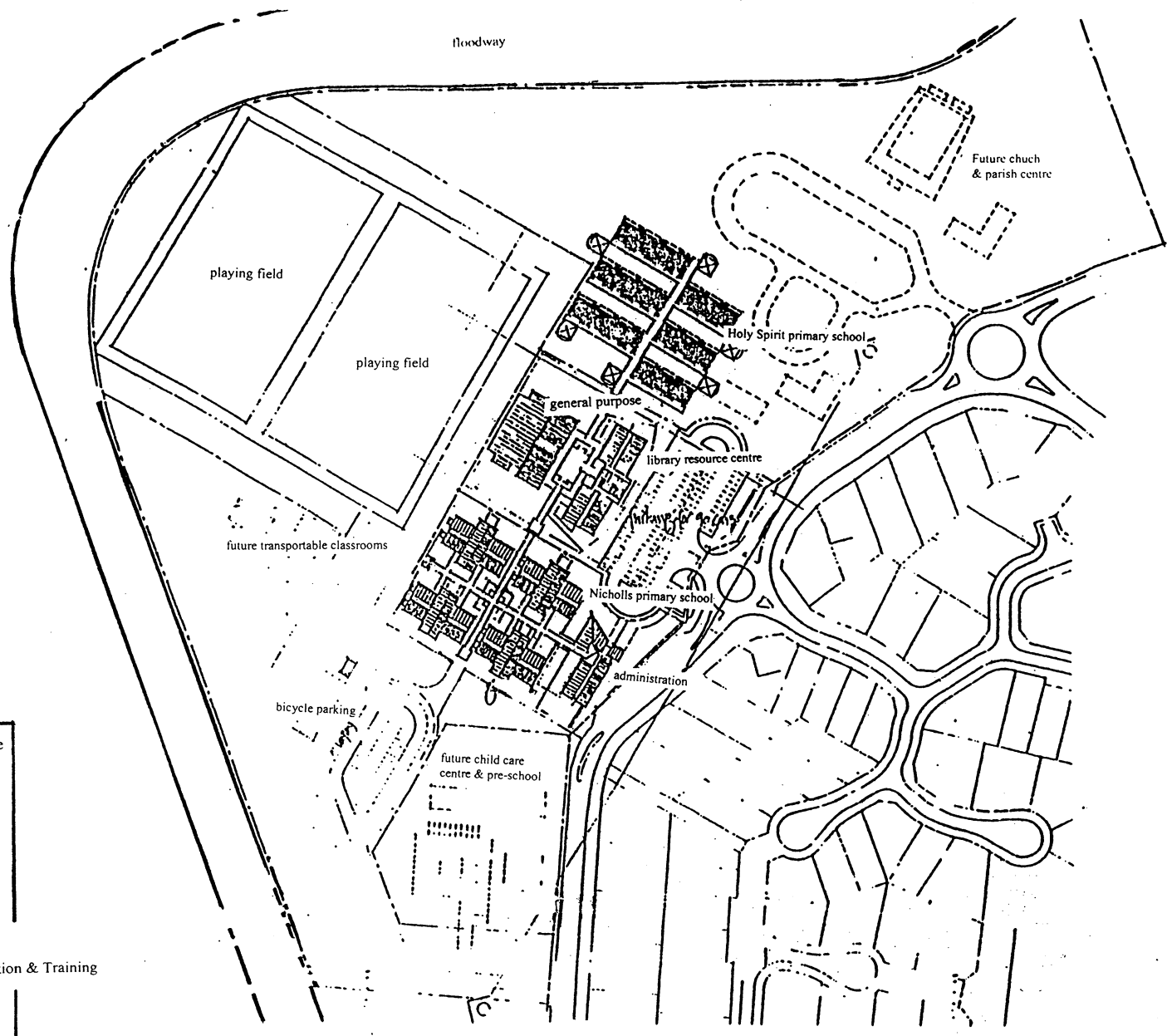

Site Allocations

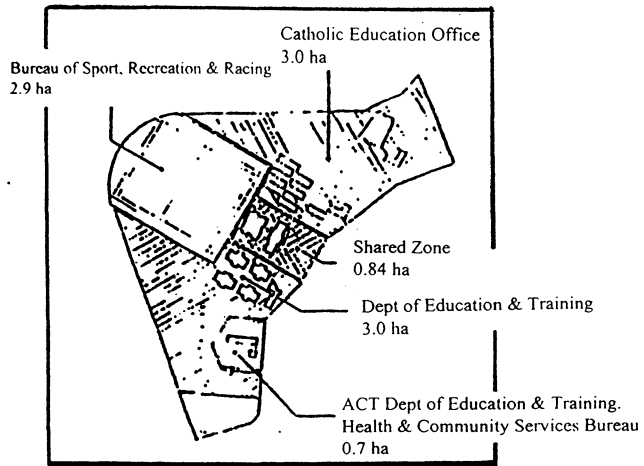

NICHOLLS PRIMARY SCHOOL, HOLY SPIRIT CATHOLIC PRIMARY SCHOOL, PRE-SCHOOL & CHILD CARE CENTRE

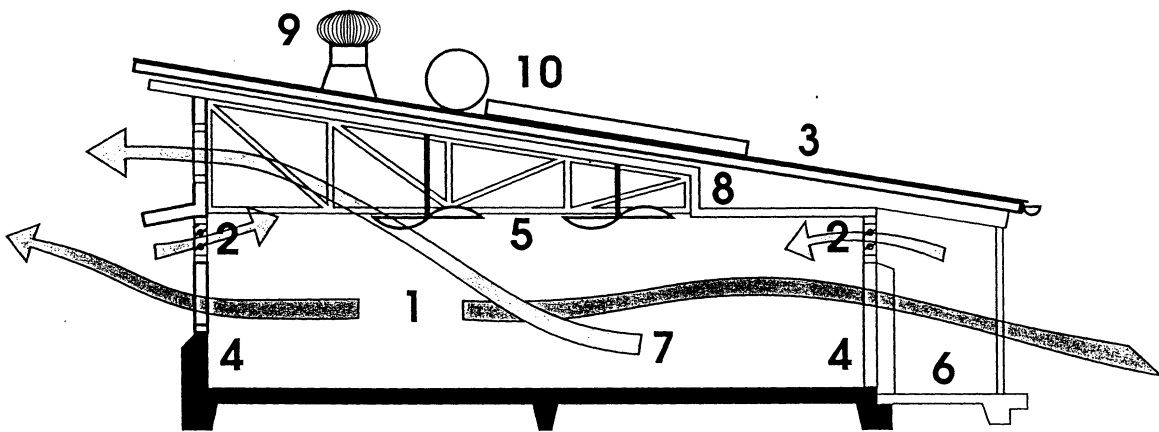

TYPICAL SECTION THROUGH CLASSROOM BLOCK

- | | | | |
|---|--|----|--|
| 1 | General cross ventilation. | 6 | Covered walkways on northern side shades walls. |
| 2 | Window can be left open for cool evening air to enter. | 7 | Hot air to escape during and after school hours. |
| 3 | Polycarbonate roofing strips allow natural light to enter. | 8 | Insulation under roof and on top of ceiling. |
| 4 | No insulation in walls. | 9 | Rooftop "turbo vent". |
| 5 | Ceiling fans improve comfort conditions. | 10 | Solar water heating. |

AMENDMENTS
 2: 16-11-93
 DRAWING AMENDED, RENUMBERED, RE
 ZA: 30-11-93
 SKYLIGHTS ADDED TO WALKWAY ELEVATION

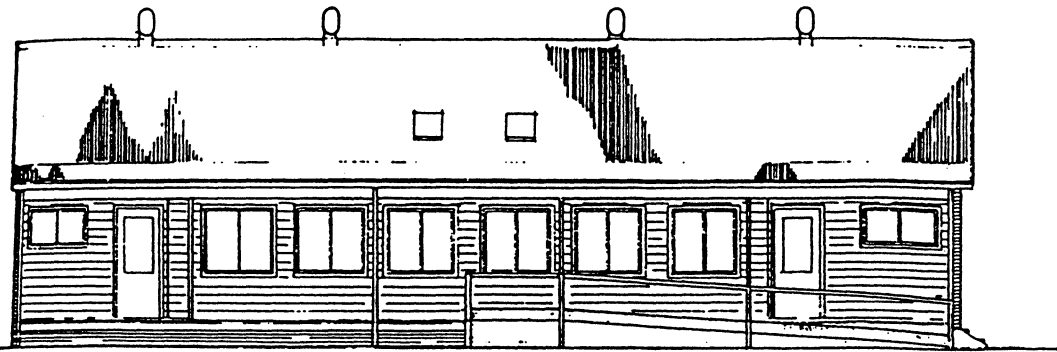

WALKWAY

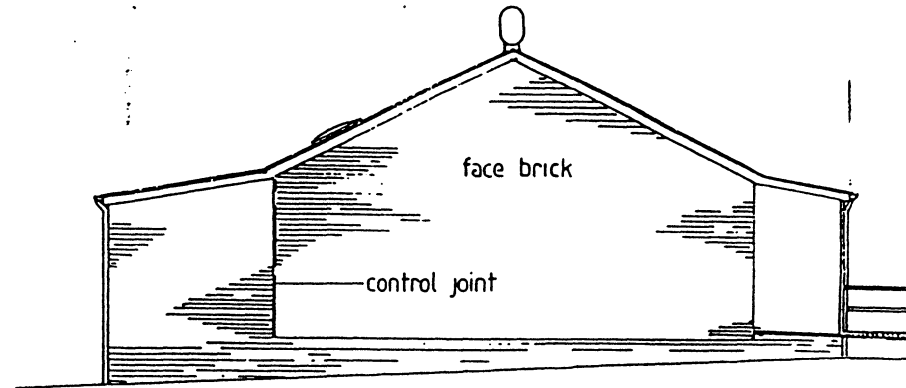

END

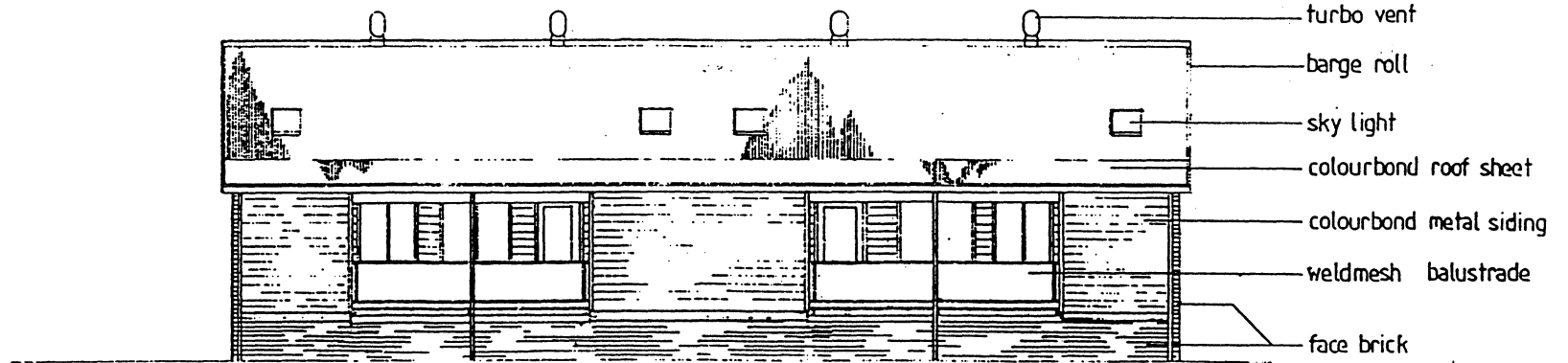

COLA

PROJECT MANAGEMENT & DESIGN BY
 CLIENT SERVICE DIVISION
 PHONE: 3728511

Design Development & Documentation
 DILLON & SAVAGE ARCHITECTS
 Phone: 977 3714



R.D. CHRISTIE
 DIRECTOR-GENERAL
 OF PUBLIC WORKS



KEN BOSTON
 DIRECTOR-GENERAL
 OF EDUCATION

HOME BASE KIT 1992
 BRICK VENEER TYPE

ELEVATIONS

SCALE 1:1

SCALES

1:100

PLAN RM. NO.

DRAWN

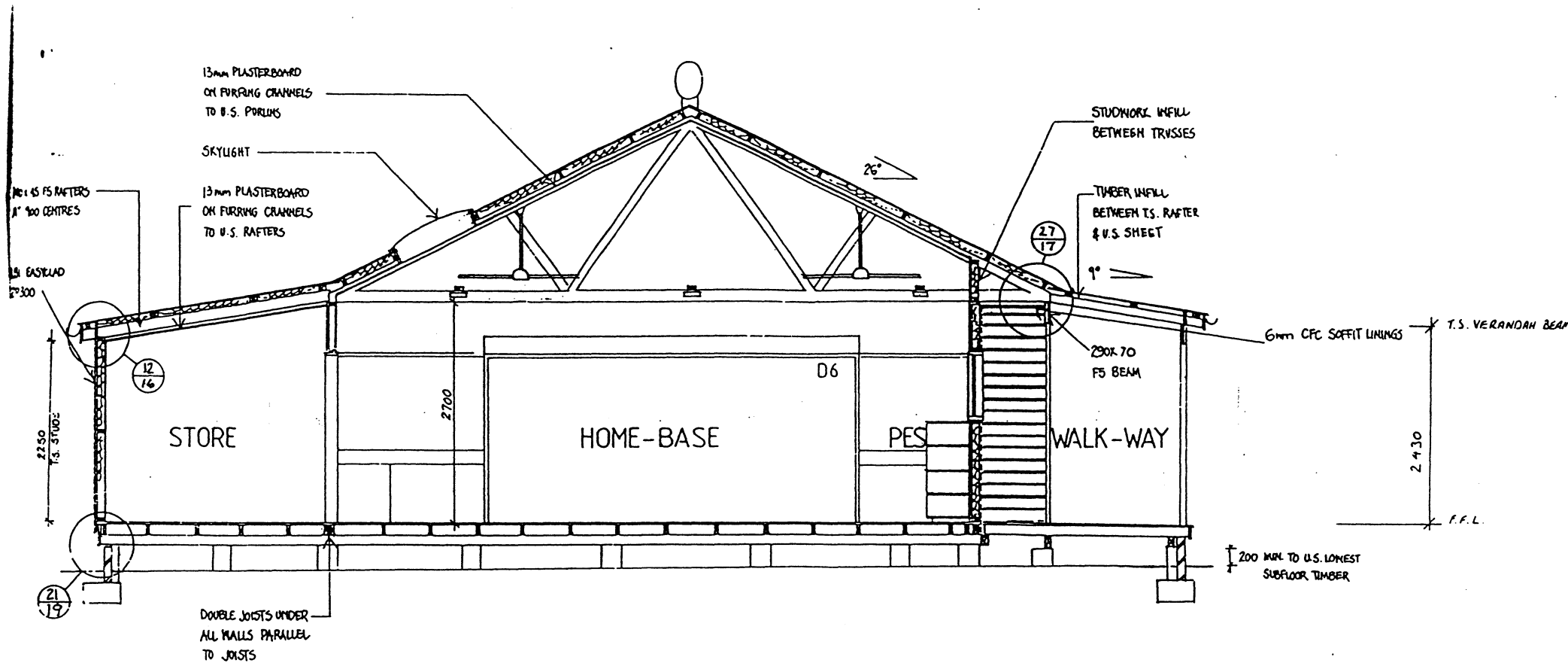

PROJECT MANAGEMENT & DESIGN BY
 CLIENT SERVICE DIVISION
 PHONE: 3728511

Design Development & Documentation
 DILLON & SAVAGE ARCHITECTS
 Phone: (02) 977 3714

 PUBLIC WORKS

R.D. CHRISTIE
 DIRECTOR-GENERAL
 OF PUBLIC WORKS



KEN BOSTON
 DIRECTOR-GENERAL
 OF SCHOOL EDUCATION

HOME BASE KIT 1992
 BRICK VENEER TYPE

SECTION BB

SCALE 1:1

SCALE 1:50

PLAN P.M. NO.

DRAWN

Z: 16-11-93
 DRAWING AMENDED, RENUMBERED &
 REISSUED
 ZA 30-11-93
 SKYLIGHTS ADDED ADJACENT TO WALKWAY

Location of ramp and stair is indicative only.
 Establish final configuration from site specific documentation.

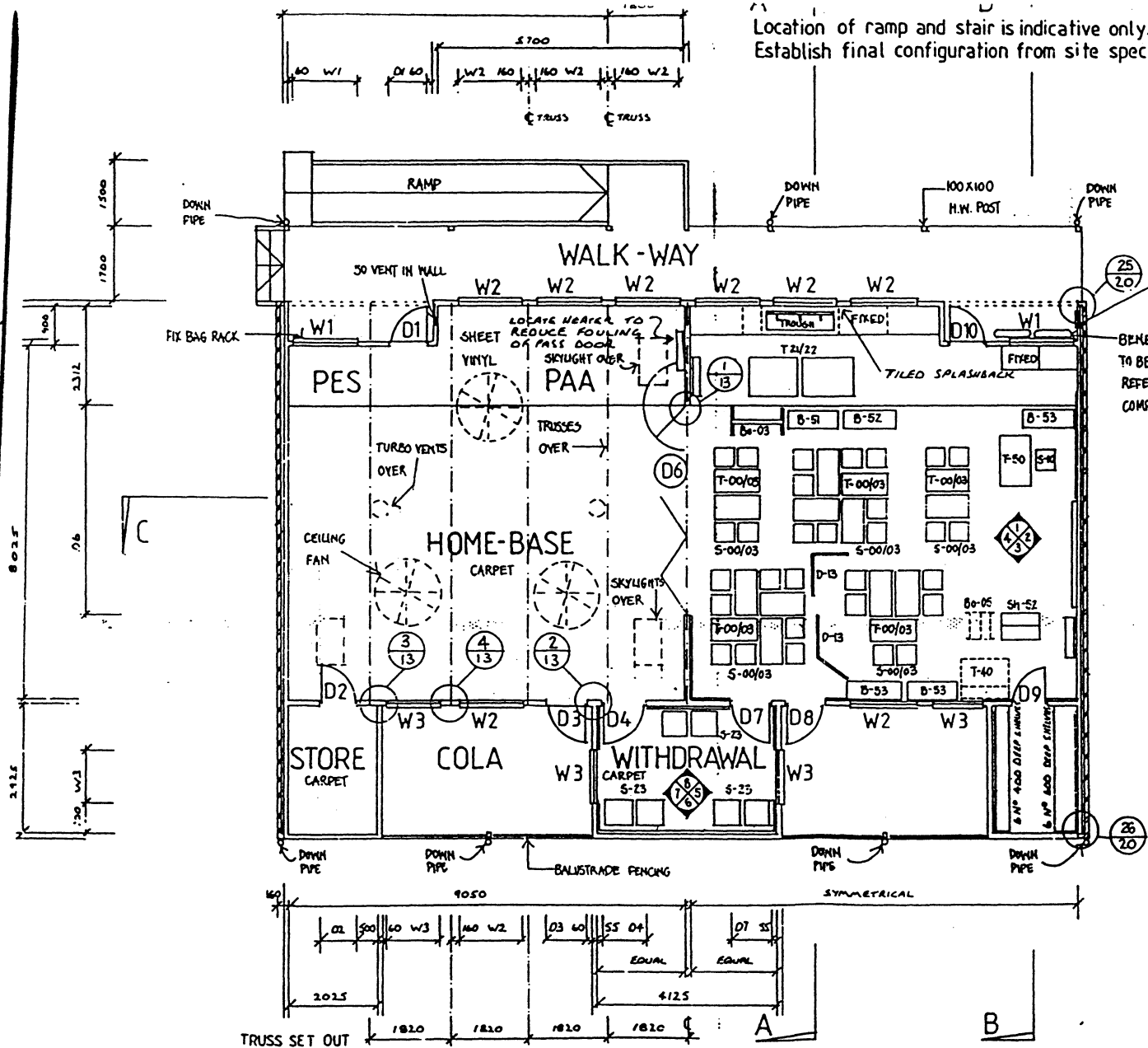

(25)
(20)
ELECTRICAL DISTRIBUTION BOARD
 BENEATH W/ FIX BAG RACK TO BE SUPPLIED BY PRINCIPAL REFER SCHOOL FURNITURE COMPLEX PRNG NO. 09 14

THE SIDES OF THE HOME BASE KIT ARE SYMMETRICAL

FITTINGS FIXTURES & FURNITURE SHOWN ON ONE SIDE ONLY SHALL BE SUPPLIED AND FITTED TO BOTH SIDES

HANDING WILL DIFFER BETWEEN SIDES

NOTE:

Dimensions locating walls are to the face of the unlined studwork

Dimensions locating openings are to reveal face of the pressed steel frames

PROJECT MANAGEMENT & DESIGN BY
 CLIENT SERVICE DIVISION
 PHONE: 3728511
 Design Development & Documentation
 DILLON & SAVAGE ARCHITECTS
 Phone: 977 3714

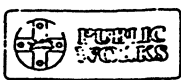

R.D. CHRISTIE
 DIRECTOR-GENERAL
 OF PUBLIC WORKS



KEN BOSTON
 DIRECTOR-GENERAL
 OF SCHOOL EDUCATION

HOME BASE KIT 1992
 BRICK VENEER TYPE

FLOOR PLAN

SCALE 1:1
SCALES 1:100
PLAN R/L NO.
DRAWN